



ULV-100

2 x 2 - 9C

100GPM UL Fire Pump System

NFPA-20 Submittal Packet

NFPA-20 Fire Pump

2-383-9C

ULV-100

Compact Residential Package
 Design Condition: 100GPM @ 75PSI

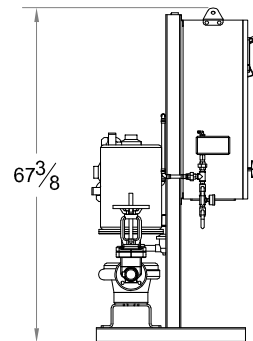
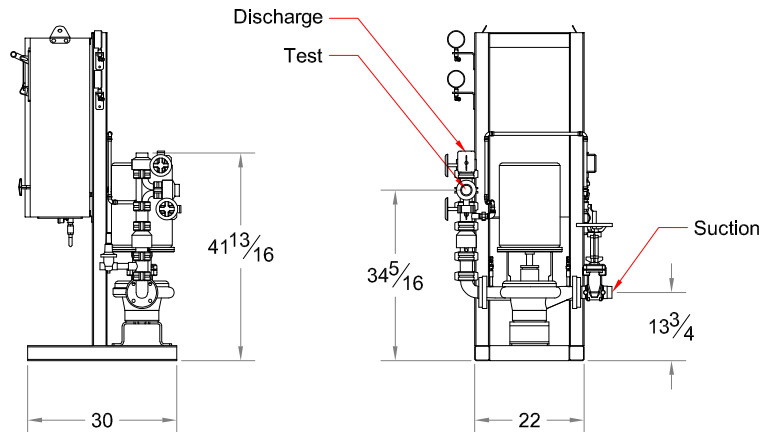
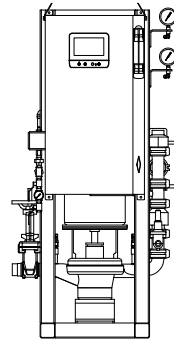
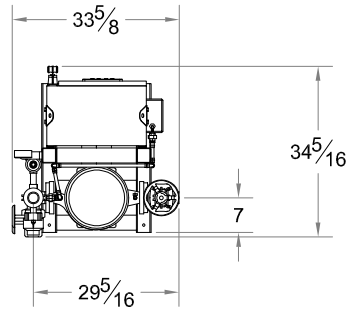
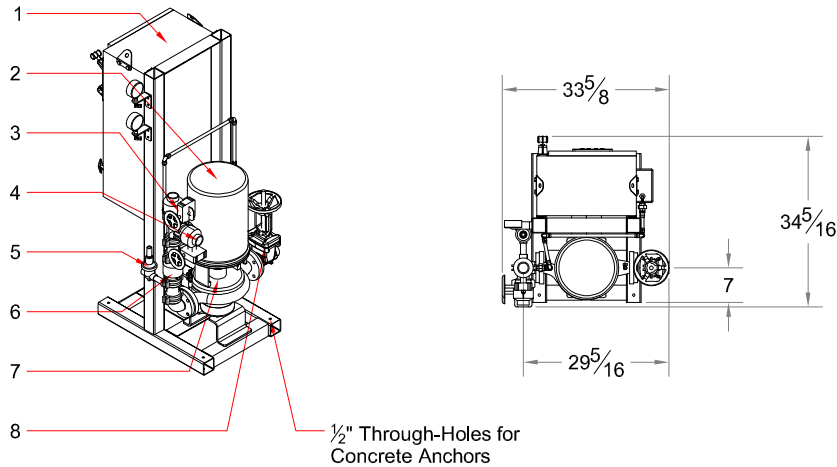

System Components per NFPA-20

System Specifications:

- Motor
- 10 Horsepower Electric
- 230 Volt, 46 Amp
- Single Phase
- 3450 RPM

Pump

- UL Vertical Inline Fire Pump
- 2" Suction (Grooved)
- 2" Discharge (Grooved)
- 2" Test Connection (Grooved)
- 175 PSI max working pressure

System Components (UL Listed by Manufacturer)

- 1- Limited Service Fire Pump Controller
- 2- Electric Motor (UL Recognized)
- 3- Discharge Butterfly Valve (Monitored)
- 4- Test Connection Butterfly Valve (Monitored)
- 5- Case Relief Valve
- 6- Check Valve
- 7- Vertical Inline Fire Pump
- 8- Suction OS&Y (Monitored)

Dimensions

- 35" Depth
- 68" Height
- 34" Width

*All dimensions are approximate and subject to change without notice.

NFPA-20 Fire Pump

2-383-9C

with Jockey Pump

ULV-100

Compact Residential Package
Design Condition: 100GPM @ 75PSI

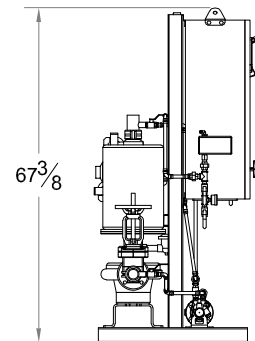
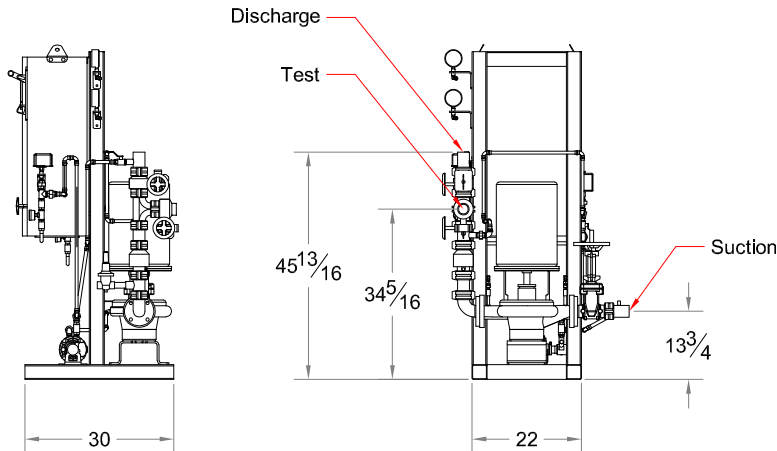
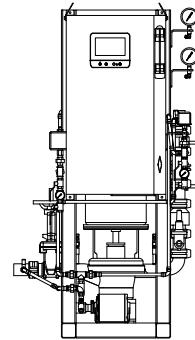
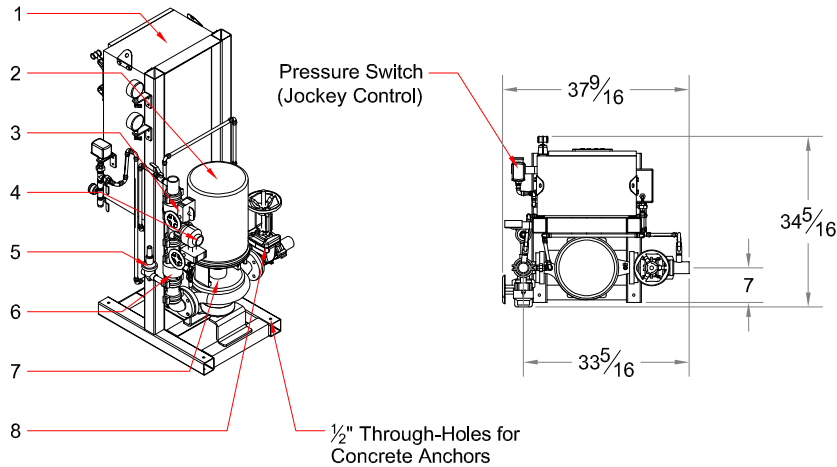

System Components per NFPA-20

System Specifications:

- Motor
- 10 Horsepower Electric
- 230 Volt, 46 Amp
- Single Phase
- 3450 RPM

Pump

- UL Vertical Inline Fire Pump
- 2" Suction (Grooved)
- 2" Discharge (Grooved)
- 2" Test Connection (Grooved)
- 175 PSI max working pressure

System Components (UL Listed by Manufacturer)

- 1- Limited Service Fire Pump Controller
- 2- Electric Motor (UL Recognized)
- 3- Discharge Butterfly Valve (Monitored)
- 4- Test Connection Butterfly Valve (Monitored)
- 5- Case Relief Valve
- 6- Check Valve
- 7- Vertical Inline Fire Pump
- 8- Suction OS&Y (Monitored)

Dimensions

- 35" Depth
- 68" Height
- 38" Width

*All dimensions are approximate and subject to change without notice.

900 Series Single Stage Inline Fire Pumps



MODEL 383



Listed

Built Per
N.F.P.A. 20

ap AURORA®

PENTAIR PUMP GROUP

Aurora 383 Series Pumps

VERTICAL Inline Close Coupled Fire Pumps are specifically designed for vertical mounting. The suction and discharge nozzles are located on the same centerline 180° apart. Vertical pumps significantly reduce required mounting space. They are easy to maintain. Simply remove eight capscrews and the motor and bracket assembly is easily removed from the casing without disturbing the piping. The impeller is direct coupled to the motor shaft for easy maintenance, to minimize impeller run out and to reduce noise.

The inline casing is heavily ribbed to resist pipe strain and is provided with a support to simplify mounting to a base or foundation. Packing is provided when suction pressure is greater than 30 PSIG; packing with lantern ring and flush line is furnished for suction pressures of 30 PSIG or less. Look through this bulletin for additional details & specifications.

Back pull-out inline case design simplifies disassembly. The suction and discharge piping or alignment is not disturbed as the casing remains in the pipeline. Simply remove the motor and bracket assembly for service or inspection.

Computer machined major components with 360° registered fits assure parts concentricity.

Note: Front case wearing rings are standard on all size pumps. Rear case rings are standard on all sizes except the 2x2x9C. The 2x2x9C does not require a wear ring.

STANDARD

Bronze fitted pump construction
Bronze shaft sleeve
Split bronze packing gland
Carbon steel shaft
125# ANSI flange drilling
Dynamically balanced vacuum cast impeller
Stainless Steel impeller screw & washer
Bronze case wearing ring(s)
Graphite impregnated acrylic packing
Motor:
NEMA-HI JP
Factory performance tested in accordance with NFPA-20

ACCESSORIES

Suction and discharge pressure gauges
Air release valve
Circulation relief valve
Hose valve header
Hose valves
Flow meter
Jockey pump
Optional flange drillings
125 lb suction - 250 lb discharge
250 lb suction and discharge

- 1 BACK PULL-OUT CASING with inline suction and discharge. design provides high efficiency and low wear for long service life.
- 2 CASE WEARING RING prevents wear on casing and is easily and inexpensively replaced.
- 3 SUPPORT simplifies mounting. The pump can be fastened to the floor, a base or foundation.
- 4 DYNAMICALLY BALANCED IMPELLER is keyed to the shaft and secured by a capscrew and washer. Vacuum casting and quality controlled manufacturing process assures consistent high performance. Enclosed
- 5 CARBON STEEL SHAFT is designed for minimum deflection at maximum load.
- 6 TWO PIECE BRONZE PACKING GLAND provides easy packing maintenance.
- 7 FACTORY PERFORMANCE TEST guarantees performance at specified pump operating conditions.
- 8 FLUSH LINE with valve (when used) from discharge provides easy water seal adjustment to lantern ring.
- 9 BRONZE SHAFT SLEEVE extends full length of stuffing box to protect motor shaft. The shaft sleeve is slip fit over the shaft and then is keylocked. Shaft sleeve and impeller screw are sealed by "O"-ring gaskets to eliminate corrosion of the shaft by the pumped liquid.
- 10 STANDARD MOTOR approved for 383 Series pump service by NEMA and the HYDRAULIC INSTITUTE provides low noise level pump operation.
- 11 VOLUTE TYPE SUCTION inlet pre-rotates suction liquid.

Vertical Fire Pump Features

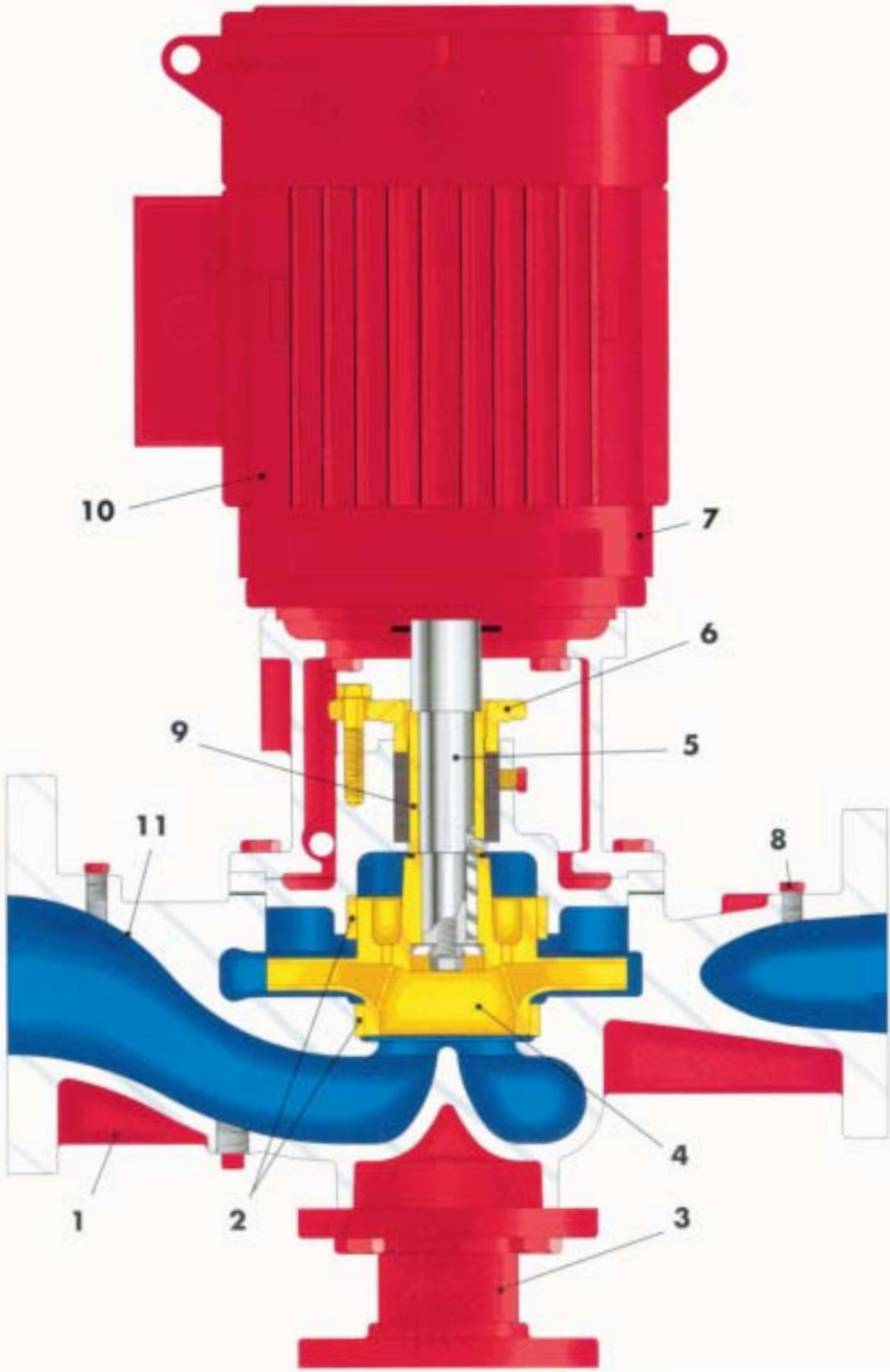



Customer : TALCO INDUSTRIES, INC.

Pump Performance Curve

Encompass 3.0 - 24.3.4

Project name : 100 @ 75

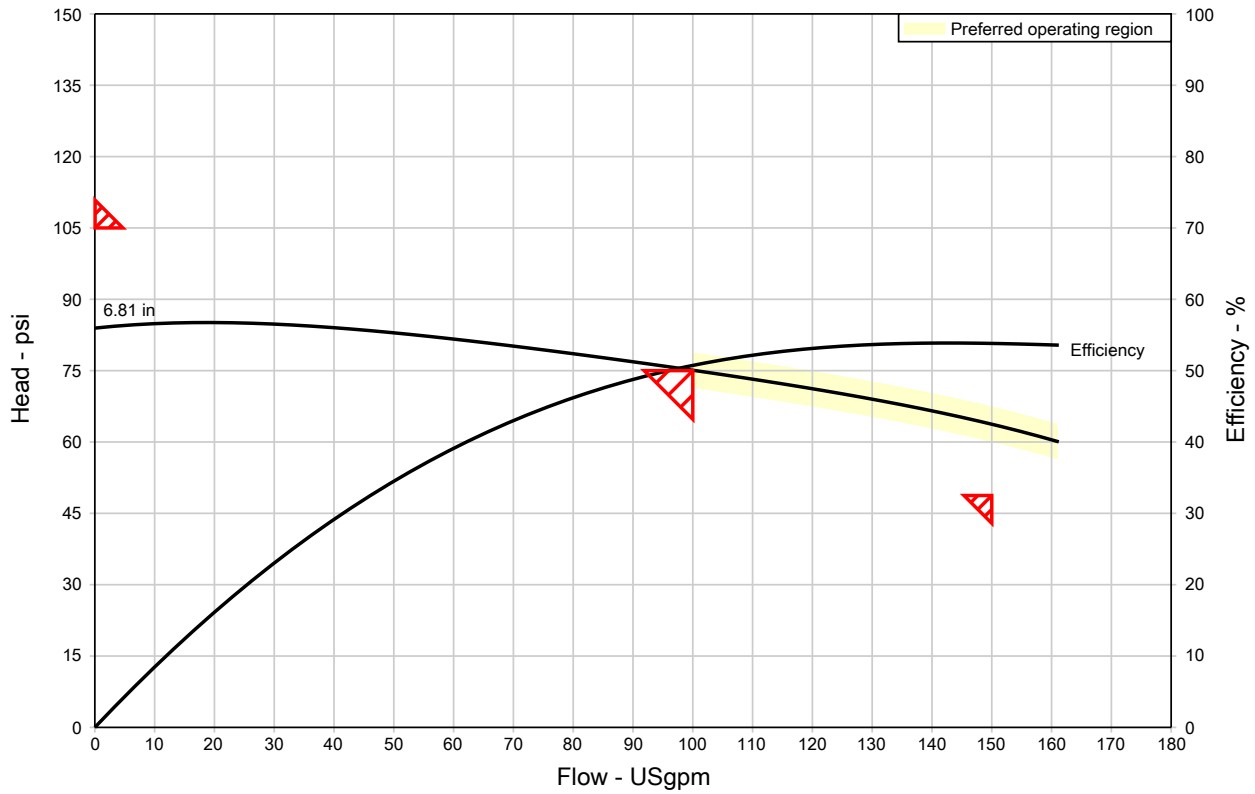
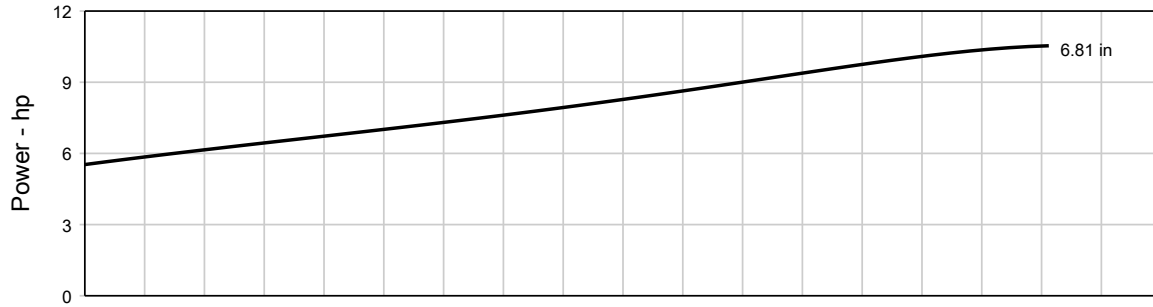

Item Number / Tags	: 001	Size	: 2-383-9C
Service	:	Stages	: 1
Quantity	: 1	Driver type	: Motor
Quote number	: 243627	Frequency	: 60 Hz
Date last saved	: 30 Oct 2024 4:46 PM	Speed, rated	: 3500 rpm
Flow, rated	: 100.0 USgpm	Based on curve number	: 383-2X2X9C-3500
Differential head / pressure, rated	: 75.00 psi	Efficiency	: 50.74 %
Flange rating (suction / discharge)	: 125/125	Max working pressure, allowable	: 175.0 psi.g
Secondary Point (150% of rated flow)	: 150.0 USgpm	Max Shutoff Head (Calculated)	: 89.00 psi
Secondary Point (65% of rated head)	: 48.75 psi	Max suction pressure, allowable	: 86.00 psi.g
Max Shutoff per NFPA	: 105.0 psi	Pump shutoff w/ suction pressure	: 99.00 psi.g
		Power driver, minimum	: 10.00 hp

General Arrangement

WARNING
 DO NOT OPERATE THIS MACHINE WITHOUT PROTECTIVE GUARD IN PLACE. ANY OPERATION OF THIS MACHINE WITHOUT PROTECTIVE GUARD CAN RESULT IN SEVERE BODILY INJURY.

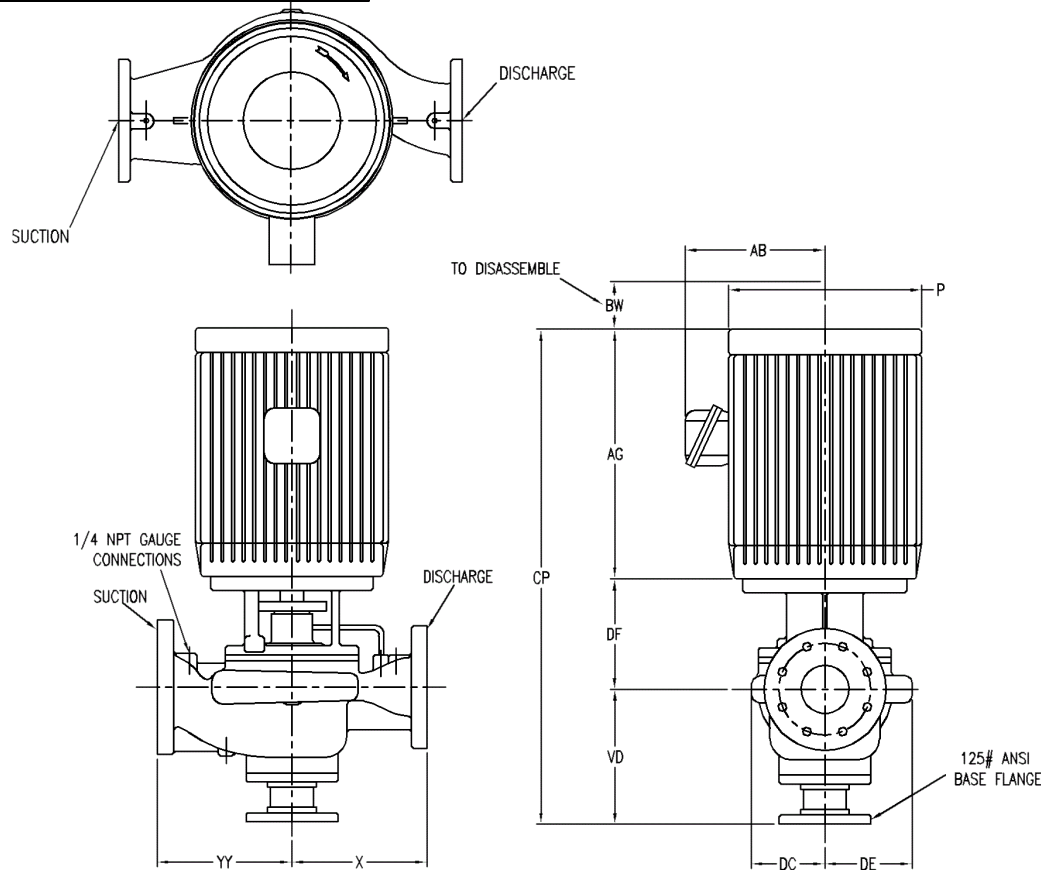

X	YY	BW	VD	DF	DC
9.50	9.50	4.50	9.25	8.63	5.75

DE	AG	P	AB	CP	Base Flange Size
6.25	17.00	12.25	7.63	35.00	2.00

NOTES:
Not for construction, installation, or application purposes unless certified.

All dimensions are in inches

Dimensions may vary ± .38" (10mm) due to normal manufacturing tolerances.

See configuration for estimated total weight.

Pump Data	
Series	Inline
Model	2-383-9C
Size	2x2x9C
Flow	100.0 USgpm
Rated Pressure	75.00 psi.g
RPM	3500 rpm
Rotation	Right handed
Liquid Type	Water
Discharge Size	2.00 in
Suction Size	2.00 in
Impeller Diameter	6.81 in
Connection Type	125/125
Base Type	Pipe flange support
-	-

Pump Materials of Construction	
Pump	Bronze fitted with Cast Iron casing
Shaft	Carbon Steel

Motor Data	
Power	10.00 hp
Phase	1
Frequency	60 Hz
Volts	230 V
RPM	3600
Frame	215JP
Service Factor	1.15
Enclosure	ODP
Manufacturer	Weg

Site Information	
Elevation	300.0 ft
Temperature	77.00 deg F

Estimated Weights	
Pump	130.0 lb
Driver	0.00 lb

Quote Information			
Customer	TALCO INDUSTRIES, INC.		
Customer Quote	0		
Job Name	Default		
Market	-		
	Quote Item	001	
	Quote Date	10 Oct 2023	

TALCO FIRE
SYSTEMS



RESIDENTIAL & COMMERCIAL FIRE PUMP SPECIALISTS

6040 NE 112TH AVE. PORTLAND, OREGON 97220

PHONE: 800-878-8055 WWW.TALCOFIRE.COM

Fire Pump Controller



TORNATECH

Project: _____

Customer: _____

Engineer: _____

Pump Manufacturer: _____

Technical Data Submittal Document

Model GPL

Limited Service Full Voltage
Across the Line Start
Electric Fire Pump Controller



Contents:

Data Sheets
Dimensional Data
Wiring Schematics
Field Connections

Note: The drawings included in this package are for controllers covered under our standard offering. Actual AS BUILT drawings may differ from what is shown in this package.



N.Y.C.
APPROVED



May 2024

From normal incoming power through Disconnecting Means (IS/CB)*

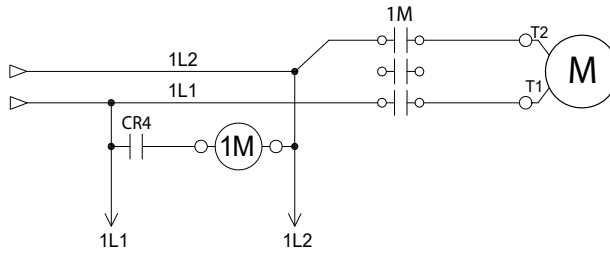

Standard, Listings, Approvals and Certifications	Built to NFPA 20 (latest edition)	
	Underwriters Laboratory (UL) • UL218 - Fire Pump Controllers	
	New York City	Accepted for use in the City of New York by the Department of Buildings
	Optional	
	CE Mark	Various EN, IEC & CEE directives and standards
Enclosure	Protection Rating Standard: NEMA 2 Optional NEMA 12 NEMA 4X-304 sst painted NEMA 3 NEMA 4X-304 sst brushed finish NEMA 3R NEMA 4X-316 sst painted NEMA 4 NEMA 4X-316 sst brushed finish	
	Accessories • Bottom entry gland plate • Lifting Lugs • Keylock handle	Paint Specifications • Red RAL3002 • Powder coating • Glossy textured finish

Shortcircuit Withstand Rating	120V to 240V - 1ph - 60Hz
Standard	100,000A



Limitations	<ul style="list-style-type: none"> • Across the line starting only • Horsepower rating of maximum 30hp • Can only be installed where acceptable by the authority having jurisdiction • Not accepted in FM insured property
Ambient Temperature Rating	<p>Standard: 4°C to 40°C / 39°F to 104°F ➔ Optional: 4°C to 55°C / 39°F to 131°F</p> <p>Controllers built in Dubai, UAE (Tornatech FZE) are supplied standard with 55°C rating.</p>
Surge Suppression	Surge arrestor rated to suppress surges above line voltage
Disconnecting Means	<ul style="list-style-type: none"> • Door interlocked in the ON position • Circuit breaker continuous rating not less than 115% of motor full load current • Overcurrent sensing non-thermal type, magnetic only • Instantaneous trip setting of not more than 20 times the motor full load current • Common flange mounted operating handle
Service Entrance Rating	Suitable as service entrance equipment
Emergency Start Handle	<ul style="list-style-type: none"> • Flange mounted • Pull and latch activation • Integrated limit switch • Across the line start (direct on line)
Locked Rotor Protector	<ul style="list-style-type: none"> • Operate shunt trip to open circuit breaker • Factory set at 600% of motor full load current • Trip between 8 and 20 seconds
Electrical Readings	<ul style="list-style-type: none"> • Voltage phase to phase (normal power) • Amperage of each phase when motor is running
Pressure Readings	<ul style="list-style-type: none"> • Continuous system pressure display • Cut-in and Cut-out pressure settings
Pressure and Event recorder	<ul style="list-style-type: none"> • Pressure readings with date stamp • Event recording with date stamp • Under regular maintained operation, events are stored in memory for the life of the controller. • Data viewable on operator interface display screen • Downloadable by USB port to external memory device
Pressure Sensing	<ul style="list-style-type: none"> • Pressure transducer and run test solenoid valve assembly for fresh water application • Pressure sensing line connection 1/2" Female NPT • Drain connection 3/8" • Rated for 0-500PSI working pressure (standard display at 0-300PSI) • Externally mounted with protective cover



Audible Alarm	Alarm buzzer - 85dB at 3 meters		
Visual Indications	<ul style="list-style-type: none"> • Power available • Motor run • Periodic test • Manual start 	<ul style="list-style-type: none"> • Deluge valve start • Remote automatic start • Remote manual start • Emergency start 	<ul style="list-style-type: none"> • Pump on demand/Automatic start • Pump room temperature (°F or °C) • Lockout
Visual & Audible Alarms	<p>Visual</p> <ul style="list-style-type: none"> • Control voltage not healthy • Invalid cut-in • Lock rotor current • Loss of power • Low ambient temperature • Low water level • Motor trouble • Phase reversal (normal power) <p>Visual and audible</p> <ul style="list-style-type: none"> • Fail to start 	<ul style="list-style-type: none"> • Overcurrent • Overvoltage • Phase loss L1 • Phase loss L2 • Phase loss L3 • Phase unbalanced • Pressure transducer fault detected 	<ul style="list-style-type: none"> • Pump on demand • Pump room alarm • Service required • Undercurrent • Undervoltage • Check weekly test solenoid • Weekly test cut-in reached
Remote Alarm Contacts	<p>DPDT-8A-250V.AC</p> <ul style="list-style-type: none"> • Power available • Phase reversal • Motor run • Common pump room alarm (field re-assignable)** <ul style="list-style-type: none"> • Overvoltage • Undervoltage • Phase unbalance • Low pump room temperature • High Pump room temperature • Common motor trouble (field re-assignable)** <ul style="list-style-type: none"> • Overcurrent • Fail to start • Undercurrent • Ground fault • Free (field programmable)** 		

**Tornatech reserves the right to use any of these three alarm points for special specific application requirements.



ViZiTouch V2.1 Operator Interface	<ul style="list-style-type: none"> • Embedded microcomputer with software PLC logic • 7.0" color touch screen (HMI technology) • Upgradable software • Multi-language 			
Communication Protocol Capability	<ul style="list-style-type: none"> • Protocol: Modbus • Connection type: Shielded female connector RJ45 • Frame Format: TCP/IP • Addresses: See bulletin MOD-GPx 			
Operation	Automatic Start	<ul style="list-style-type: none"> • Start on pressure drop • Remote start signal from automatic device • Deluge valve start 		
	Manual Start	<ul style="list-style-type: none"> • Start pushbutton • Run test pushbutton • Remote start from manual device 		
	Stopping	<ul style="list-style-type: none"> • Manual with Stop pushbutton • Automatic after expiration of minimum run timer *** 		
	Timers	Field Adjustable & Visual Countdown	<ul style="list-style-type: none"> • Minimum run timer ***(off delay) • Sequential start timer (on delay) • Periodic test timer 	
	Actuation	Visual Indication	<ul style="list-style-type: none"> • Pressure • Non-pressure 	
	Mode		<ul style="list-style-type: none"> • Automatic • Non-automatic 	

***Can only be used if approved by the AHJ



A4	Flow switch provision
A8	Foam pump application w/o pressure transducer and run test solenoid valve.
A9	Low zone pump control function
A10	Middle zone pump control function
A11	High zone pump control function
A13	Non-pressure actuated controller w/o pressure transducer and run test solenoid valve
A16	Lockout/interlock circuit from equipment installed inside the pump room
B11	Built in alarm panel (120V.AC supervisory power) providing indication for: • Audible alarm & silence pushbutton for motor run, phase reversal, loss of phase. • Pilot lights for loss of phase & supervisory power available
B11B	Built in alarm panel same as B11 but 220-240VAC supervisory power
B19A	High motor temperature c/w thermostat relay and alarm contacts (DPDT)
B19B	High motor temperature c/w PT100 relay and alarm contacts (DPDT)
B21	Ground fault alarm detection c/w visual indication and alarm contact (DPDT)
C1	Extra motor run alarm contact (DPDT)
C4	Periodic test alarm contact (DPDT)
C6	Low discharge pressure alarm contact (DPDT)
C7	Low pump room temperature alarm contact (DPDT)
C10	Low water reservoir level alarm contact (DPDT)
C11	High electric motor temperature alarm contact (DPDT)
C12	High electric motor vibration c/w visual indication and alarm contact (DPDT)
C14	Pump on demand / automatic start alarm contact (DPDT)
C15	Pump fail to start alarm contact (DPDT)
C16	Control voltage healthy alarm contact (DPDT)
C17	Flow meter valve loop open c/w visual indication and alarm contact (DPDT)
C18	High water reservoir level c/w visual indication and alarm contact (DPDT)

C19	Emergency start alarm contact (DPDT)
C20	Manual start alarm contact (DPDT)
C21	Deluge valve start alarm contact (DPDT)
C22	Remote automatic start alarm contact (DPDT)
C23	Remote manual start alarm contact (DPDT)
C24	High pump room temperature alarm contact (DPDT)
C25	Second set of standard alarm contacts (DPDT) (Typical for city of Los Angeles and Denver)
Cx	Additional visual and alarm contact (Specify function) (DPDT)
D1	Low suction pressure transducer for fresh water rated at 0-300PSI with visual indication and alarm contact
D1A	Low suction pressure transducer for sea water rated at 0-300PSI with visual indication and alarm contact
D13A	High withstand rating for • 380V to 480V = 65kA* • 600V = 25kA*
D14	Anti-condensation heater & thermostat
D14A	Anti-condensation heater & humidistat
D14B	Anti-condensation heater & thermostat & humidistat
D15	Tropicalization
D18	CE Mark with factory certificate
D26	Modbus with RTU frame format and RS485 connection
D27	Motor heater connection (external single phase power source and heater on/off contact)
D27A	Motor heater connection (internal single phase power source and heater on/off contact)
D28	Customized drawing set
D34A	Field programmable I/O board - 5 Input / 5 output
D36	Redundant pressure transducer for fresh water rated for 0-500PSI
D36A	Redundant pressure transducer for sea water rated for 0-500PSI

Note: Options chosen from this page are not electrically represented on the wiring schematics in this submittal package.

L01	Other language and English (bilingual)
L02	French
L03	Spanish
L04	German
L05	Italian
L06	Polish
L07	Romanian
L08	Hungarian
L09	Slovakian
L10	Croatian
L11	Czech
L12	Portuguese
L13	Dutch
L15	Turkish
L16	Swedish
L21	Danish
L25	Chinese
L28	Finnish
L29	Norwegian

Additional Options:

Note: Options chosen from this page are not electrically represented on the wiring schematics in this submittal package.

ViZiTouch V2.1 Operator Interface

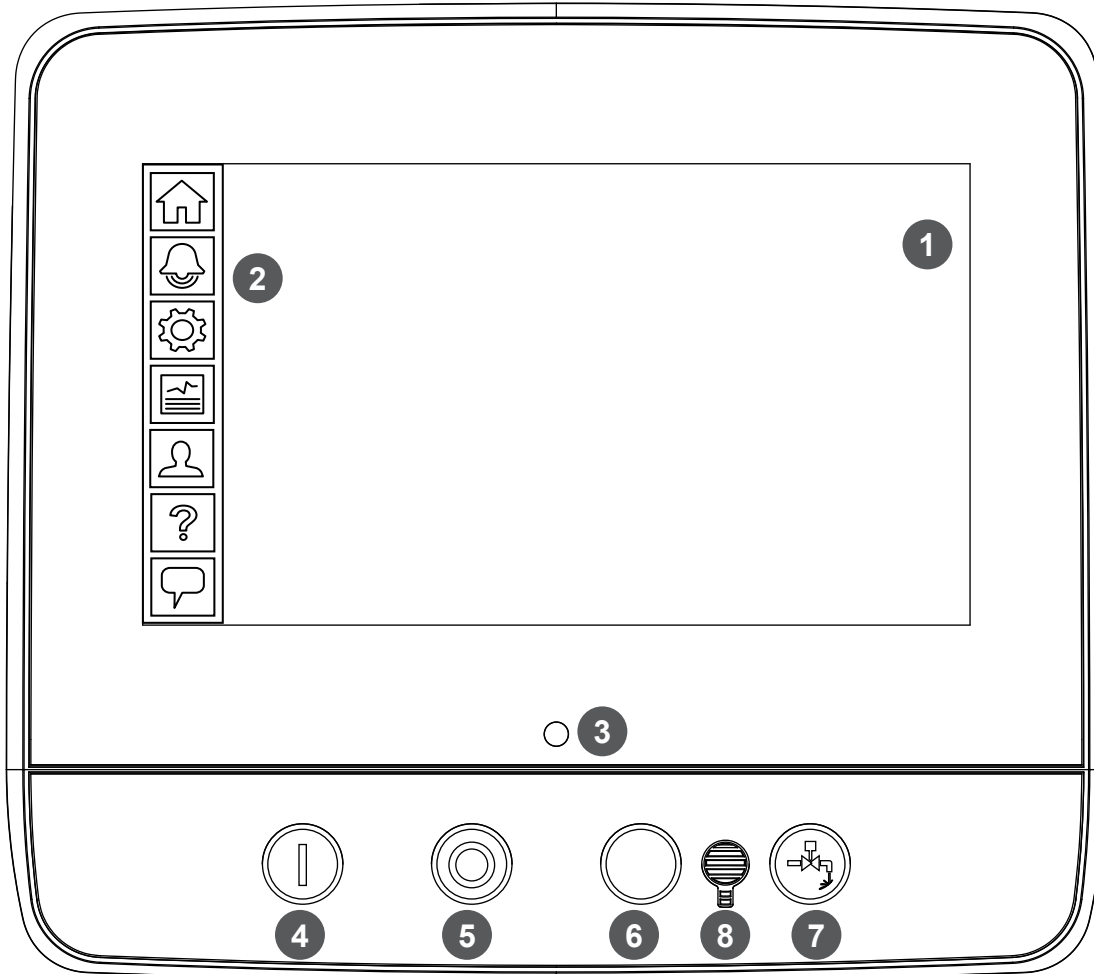

- | | |
|------------------------|--------------------------|
| 1 - Color touch screen | 3 - Power LED (3 colors) |
| 2 - Onscreen menu | 4 - START button |
| • HOME page | 5 - STOP button |
| • ALARM page | 6 - Not Used |
| • CONFIGURATION page | 7 - RUN TEST button |
| • HISTORY page | 8 - Alarm buzzer |
| • SERVICE page | |
| • MANUAL page | |
| • LANGUAGES page | |



© Tornatech, Inc. Not for construction.
Subject to change without notice.

	BY	DD/MM/YY
DRAWN BY	ACD	28/02/23
FINAL APPROVAL	FC	28/02/23

LIMITED SERVICE PUMP CONTROLLER

MODEL: GPL

BUILT TO THE LATEST EDITION OF THE NFPA20 & NFPA70



THIRD ANGLE
PROJECTION

DRAWING NUMBER	GPL-D1800/E
DWG REV. 0	
SHEET 1 OF 1	

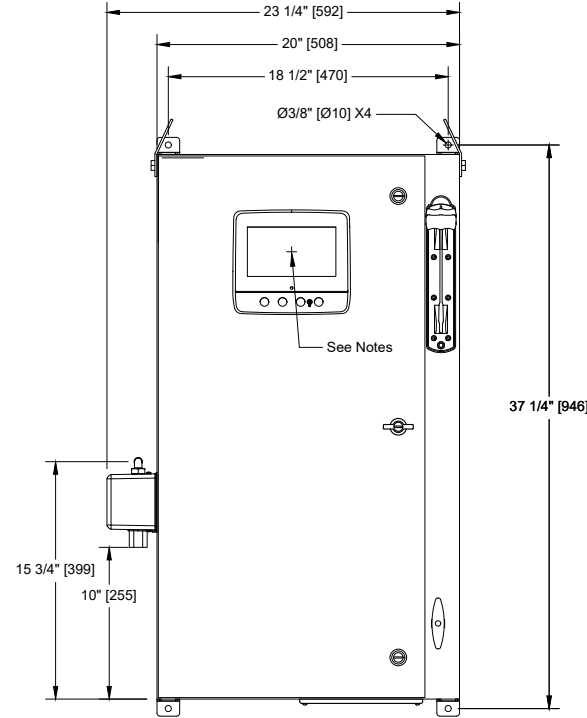
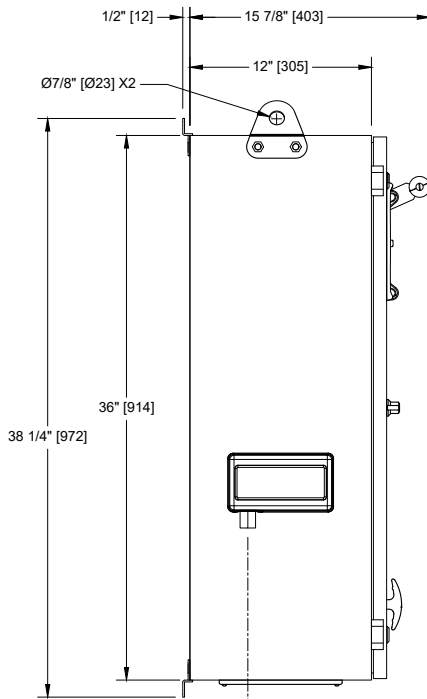

Voltage / Power Table		
Voltage	Min HP	Max HP
1 Phase		
110 - 120	1	7.5
208	3	15
220 - 240	3	15
3 Phases		
208	3	30
220 - 240	3	30
380 - 400 - 415	3	30
440 - 480	3	30
600	3	30

Sensing Line Connection - 1/2" F.NPT

Notes:

- Standard NEMA: NEMA 2
- Standard paint : textured red RAL 3002.
- All dimensions are in inches [millimeters].
- Center of screen: 29-5/8" [751] from bottom (no feet).
- Bottom conduit entrance through removable gland plate recommended.
- Use watertight conduit and connector only.
- Protect equipment against drilling chips.
- Door swing equal to door width.

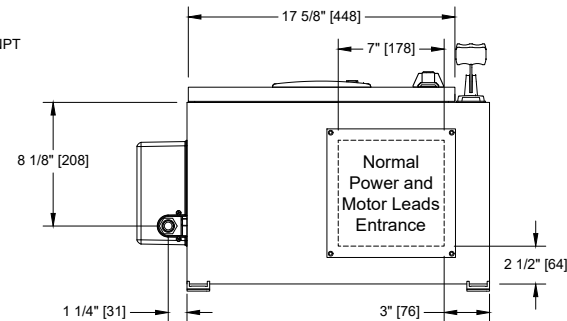



© Tornatech, Inc. Not for construction.
Subject to change without notice.

	BY	DD/MM/YY
DRAWN BY	ACD	28/02/23
FINAL APPROVAL	FC	28/02/23

LIMITED SERVICE PUMP CONTROLLER ACROSS THE LINE / 1 PHASE

MODEL: GPL

BUILT TO THE LATEST EDITION OF THE NFPA20 & NFPA70



DRAWING NUMBER	GPL-WS800/E
DWG REV. 0	
SHEET 1 OF 2	

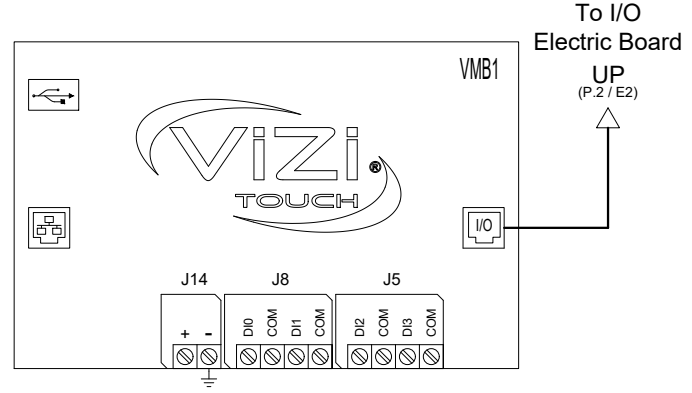
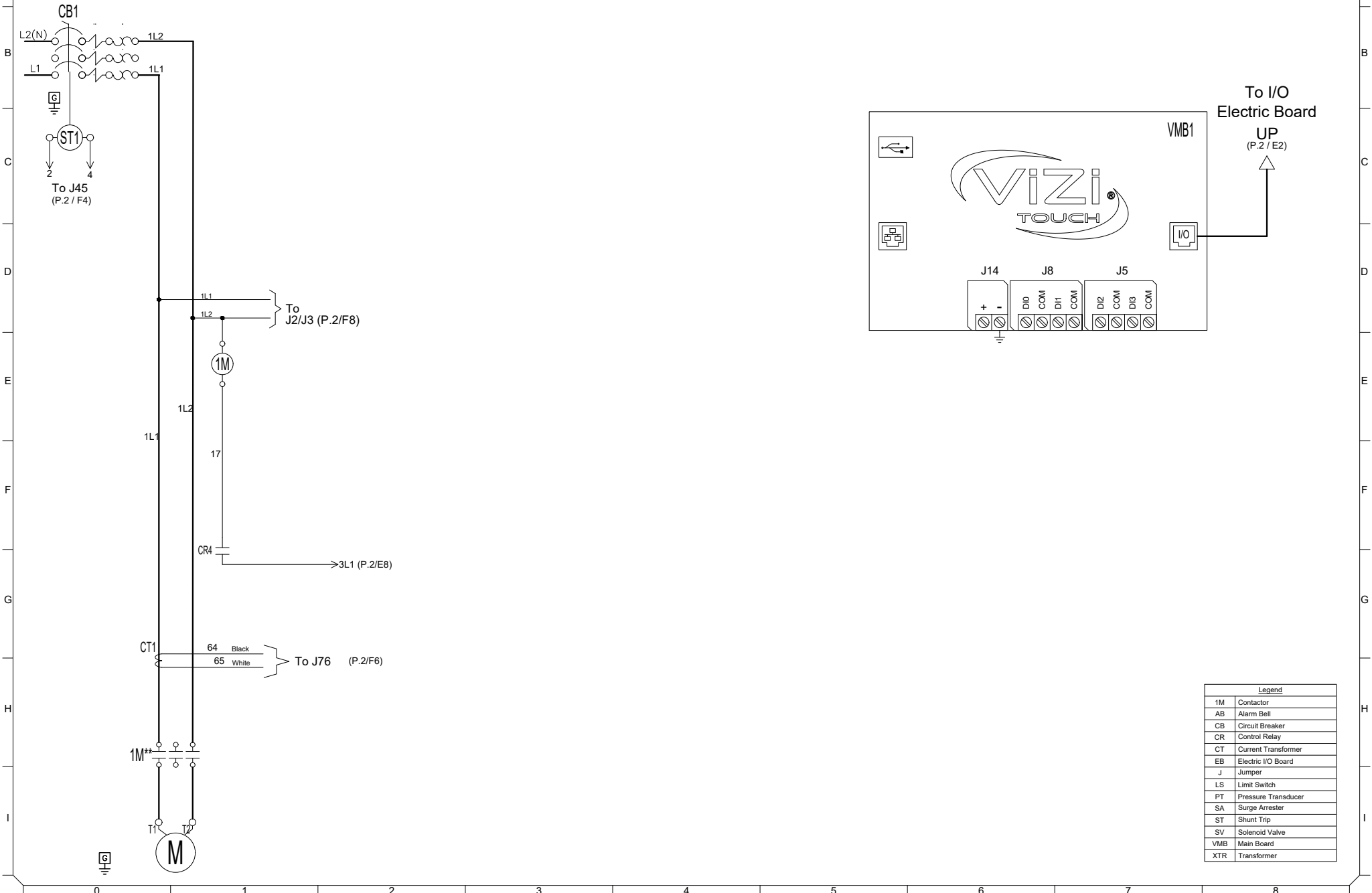

Legend	
1M	Contactors
AB	Alarm Bell
CB	Circuit Breaker
CR	Control Relay
CT	Current Transformer
EB	Electric I/O Board
J	Jumper
LS	Limit Switch
PT	Pressure Transducer
SA	Surge Arrester
ST	Shunt Trip
SV	Solenoid Valve
VMB	Main Board
XTR	Transformer



© Tornatech, Inc. Not for construction.
Subject to change without notice.

BY DD/MM/YY	
DRAWN BY	ACD 28/02/23
FINAL APPROVAL	FC 28/02/23

LIMITED SERVICE PUMP CONTROLLER ACROSS THE LINE / 1 PHASE

MODEL: GPL

BUILT TO THE LATEST EDITION OF THE NFPA20 & NFPA70



DRAWING NUMBER	GPL-WS800/E
DWG REV. 0	
SHEET 2 OF 2	

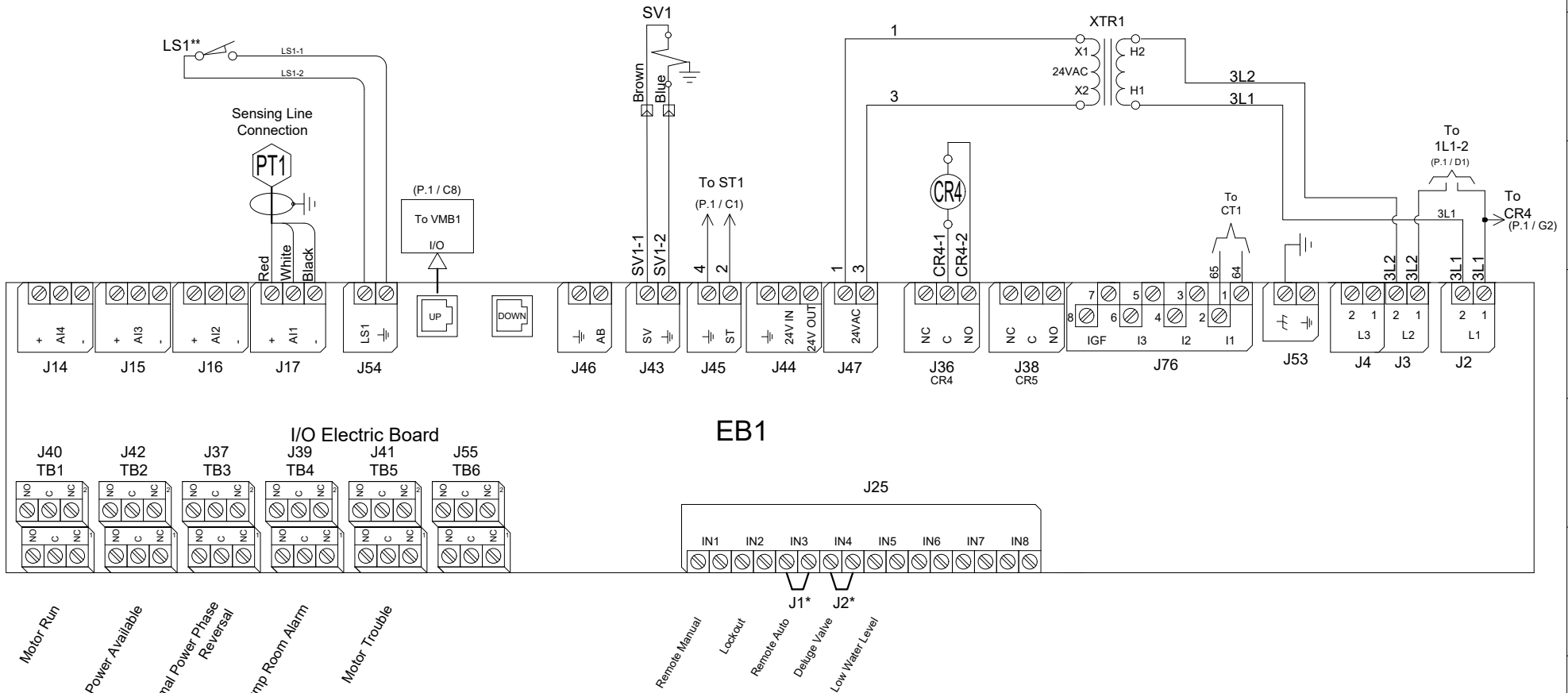

* Remove jumper to use this feature
** Contact closes when emergency start is in "ON" position



BY DD/MM/YY

DRAWN BY ACD 28/02/23

FINAL APPROVAL FC 28/02/23

© Tornatech, Inc. Not for construction. Subject to change without notice.

LIMITED SERVICE PUMP CONTROLLER

MODEL: GPL

BUILT TO THE LATEST EDITION OF THE NFPA20 & NFPA70



DRAWING NUMBER
GPL-TD800/E
DWG REV. 0
SHEET 1 OF 1

Power Terminals Model : GPL 1 Phase

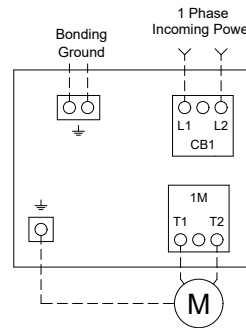

Notes:

- 1 - For proper wire sizing, refer to NFPA70 and NEC (USA) or CEC (Canada) or local code.
- 2 - Controller suitable for service entrance in USA.
- 3 - For more accurate motor connections refer to motor manufacturer or motor nameplate.
- 4 - Controller is phase sensitive. Incoming lines must be connected in ABC sequence.
- 5 - Field wiring and lug sizes are based on copper conductors only. Do not use aluminum conductors.

Circuit breaker (CB) Field Wiring according to Bending Space (AWG or MCM). TERMINALS L1 - L2

Bending Space	3" (76 mm)					
HP	1	3	5	7.5	10	15
120	1x (10 to 1)	1x (8 to 1)	1x (6 to 1)	1x (4 to 1)	N/A	N/A
208	N/A	1x (10 to 1)	1x (8 to 1)	1x (6 to 1)	1x (4 to 1)	1x (3 to 1)
220 to 240	N/A	1x (10 to 1)	1x (8 to 1)	1x (8 to 1)	1x (6 to 1)	1x (3 to 1)

(Use Copper Conductors Only)

Wiring Size for motor connection for Model GPL (AWG or MCM). TERMINALS T1 - T2

HP	1	3	5	7.5	10	15
120	1x (10 to 1)	1x (8 to 1)	1x (6 to 1)	1x (4 to 1)	N/A	N/A
208	N/A	1x (10 to 1)	1x (8 to 1)	1x (6 to 1)	1x (4 to 1)	1x (3 to 1)
220 to 240	N/A	1x (10 to 1)	1x (8 to 1)	1x (8 to 1)	1x (6 to 1)	1x (3 to 1)

(Use Copper Conductors Only)

Drawing for information only.
Manufacturer reserves the right to modify this drawing without notice.
Contact manufacturer for "As Built" drawing.



© Tornatech, Inc. Not for construction.
Subject to change without notice.

BY		DD/MM/YY	
DRAWN BY	ACD	28/02/23	
FINAL APPROVAL	FC	28/02/23	

LIMITED SERVICE PUMP CONTROLLER

MODEL: GPL

BUILT TO THE LATEST EDITION OF THE NFPA20 & NFPA70



DRAWING NUMBER
GPX-TD802/E
DWG REV. 0
SHEET 1 OF 1

Field Connections

Terminals Wire Size:
24 - 12 AWG
0.5 Nm

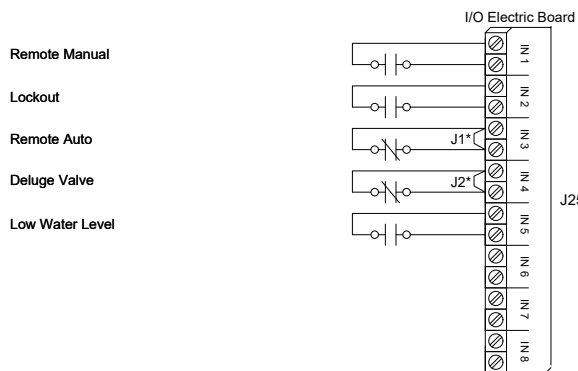

Network Connections

Terminals Wire Size:
Shielded Female Connector RJ45

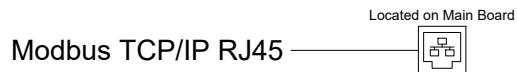

Alarm Contacts

Terminals Wire Size:
24 - 12 AWG
0.5 Nm

Motor Run

Power Available

Normal Power
Phase Reversal

Pump Room Alarm**

Motor Trouble**

(Field
Programmable)

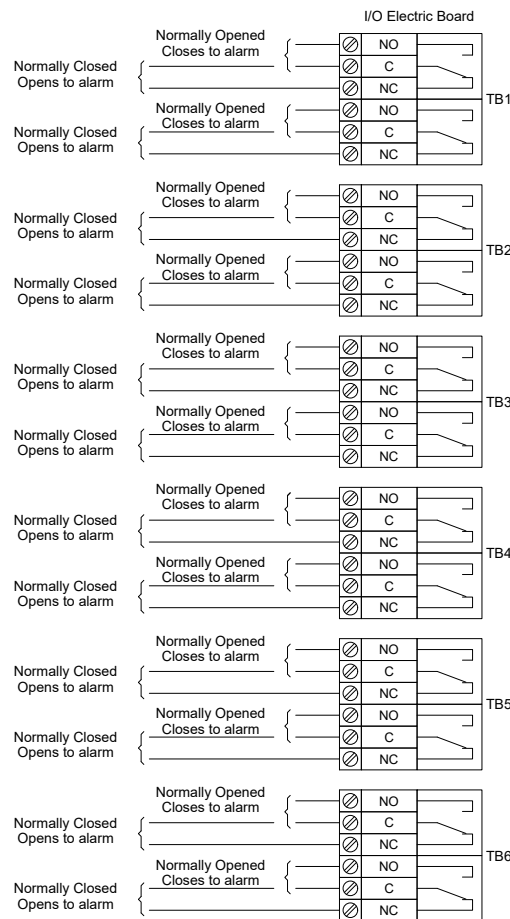

* Remove jumper to use this feature
** Re-assignable

TALCO FIRE
SYSTEMS



RESIDENTIAL & COMMERCIAL FIRE PUMP SPECIALISTS

6040 NE 112TH AVE. PORTLAND, OREGON 97220

PHONE: 800-878-8055 WWW.TALCOFIRE.COM

Jockey Pump

(Optional Equipment)

Talco ULV Jockey Pump

- High Quality Rotary Vane Pump
 - 1.8GPM @ 240PSI
- 1/3HP* 200V-240V Electric Motor
 - Resilient Mounted
 - Permanently Lubricated
- Integrated Recirculation Relief Valve
 - Factory Set to 170PSI
 - No External Discharge
- Removable Mesh Suction Strainer
 - Cleanable & Reusable

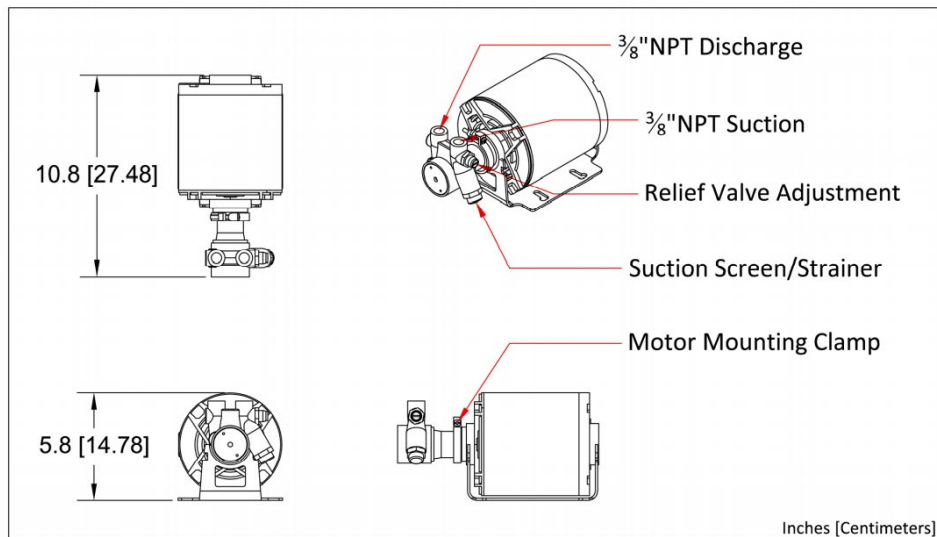

Dimensions are approximate.

*Motor HP subject to change without notice based on availability.

503-688-1231 www.talcofire.com 6040 NE 112th Ave, Portland OR

TALCO
— FIRE SYSTEMS —

Commercial Pressure Switches

Electromechanical Square D Brand 9013
For power circuits G
2-pole 2 N/C contacts
Degree of protection IP20, NEMA Type 1, 7 & 9

Flange Style

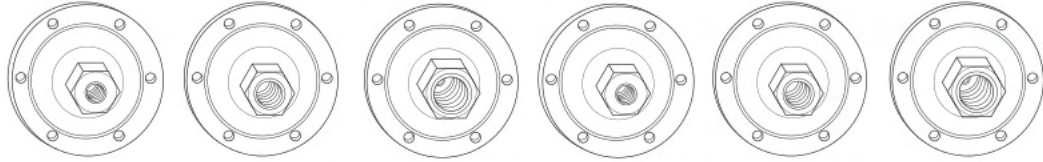

Adjustable range of switching point
Contacts open on rising pressure
2 Pole

Fluid connections	1/8" NPSF internal	1/4" NPSF internal	3/8" NPSF internal	1/8" NPSF internal	1/4" NPSF internal	3/8" NPSF internal
-------------------	--------------------	--------------------	--------------------	--------------------	--------------------	--------------------

References

NEMA Type 1, IP20	9013GHG1	9013GHG2	9013GHG3			
NEMA Type 7, NEMA Type 9				9013GHR1	9013GHR2	9013GHR3
Fluids / Pressure controlled	Water or Air	Water or Air	Water or Air	Water or Air	Water or Air	Water or Air
Pressure range						
Cut-Out PSIG (bar)	60-200	60-200	60-200	65-200	65-200	65-200
Cut-In PSIG (bar)	40-170	40-170	40-170	35-150	35-150	35-150
Weight lbs (kg)	2 lbs (0.91)	2 lbs (0.91)	2 lbs (0.91)	8 lbs (3.62)	8 lbs (3.62)	8 lbs (3.62)

Complementary characteristics not shown under general characteristics

Differential PSIG (bar)	20-40 (1.4-2.8)	20-40 (1.4-2.8)	20-40 (1.4-2.8)	30-50 (2.1-3.5)	30-50 (2.1-3.5)	30-50 (2.1-3.5)
Maximum permissible pressure PSIG (bar)	80 (5.5)	80 (5.5)	80 (5.5)	80 (5.5)	80 (5.5)	200 (13.8)
Mechanical life	300,000 operating cycles					
Cable entry	3 Conduit 1/2" Knockouts	3 Conduit 1/2" Knockouts	3 Conduit 1/2" Knockouts	2 3/4"-14 NPT	2 3/4"-14 NPT	2 3/4"-14 NPT
Pressure switch type	Diaphragm					

Ordering Information

Pressure Codes

Below is the pressure code table.
Existence of a code does not imply that the code is available for any or all devices.

Settings	Code
20-40 PSI	J20
30-50 PSI	J21
40-20 PSI	J23
40-60 PSI	J24
60-80 PSI	J25
70-90 PSI	J26
70-100 PSI	J28
75-100 PSI	J29
80-100 PSI	J30
90-120 PSI	J31
100-80 PSI	J51
100-125 PSI	J53
110-125 PSI	J54
110-150 PSI	J56
120-150 PSI	J57
125-150 PSI	J58
125-175 PSI	J60
130-175 PSI	J61
140-170 PSI	J66
140-175 PSI	J62
145-175 PSI	J63
150-120 PSI	J64
150-175 PSI	J67
215-250 PSI	J65
Specify pressure settings	J99

- Specify Class 9013 Type G.
- Select pressure code and add code designation to end of type number. Be sure that pressure code falls within the limits of the device as shown in the device listings.
- If special features are desired, add the appropriate Form letter to the Class and Type. Arrange Form letters in alphabetical sequence when ordering more than one special feature.
- Place packaging code at end of sequence with other forms when ordering. If no packaging code is indicated, devices will be shipped individually packaged.
For standard pack of 10 devices per box C10
Available on GHG, GHG, GSB, and GSG

See page 25 for Form C10.

TALCO FIRE
SYSTEMS



RESIDENTIAL & COMMERCIAL FIRE PUMP SPECIALISTS

6040 NE 112TH AVE. PORTLAND, OREGON 97220

PHONE: 800-878-8055 WWW.TALCOFIRE.COM

Valves & Fittings

**OS&Y RESILIENT SEAT GATE VALVE 2"-12"
GROOVE END**

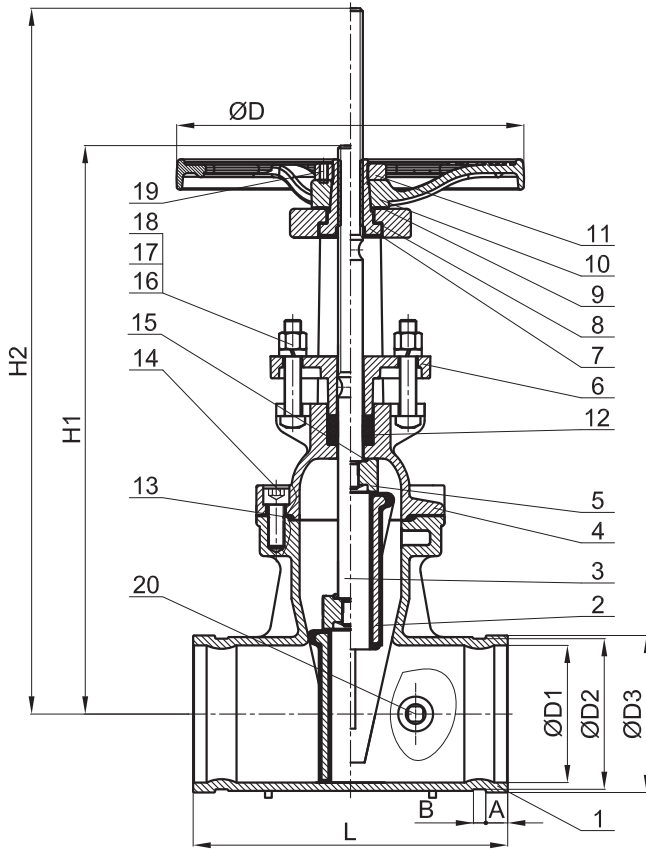

NOTE:

1. JOINT: GROOVED AWWA C606 .
2. WORKING TEMPERATURE: 0°C~65°C.
3. DESIGN STANDARD: AWWA C515.
4. WORKING PRESSURE: 300PSI.

Item	Name	Material
1	Body	ASTM A536 65-45-12
2	Wedge	ASTM A536 65-45-12 + EPDM
3	Stem	AISI SS304/SS420
4	Bonnet	ASTM A536 65-45-12
5	Disc Nut	ASTM A351 CF8
6	Gland	ASTM A536 65-45-12
7	Stem Nut	ASTM B62
8	Stem Nut Washer	ASTM B16
9	Handwheel Washer	ASTM B16
10	Handwheel	ASTM A536 65-45-12
11	Handwheel Nut	Carbon Steel Galvanzation
12	Packing	PTFE
13	Gasket	EPDM
14	Hex. Socket Cap Screw	8.8 Rating
15	O-Ring	EPDM
16	Nut	ASTM SS304
17	SQ Bolt	ASTM SS304
18	Spring Washer	ASTM SS304
19	Hex Cylinder Head Set Screws	ASTM SS304
20	Plug	ASTM SS304

SIZE	2	2.5	3	4	5	6	8	10	12
L	7.01	7.52	7.99	9.02	10.00	10.75	11.50	12.99	14.02
H1	13.27	13.27	14.80	16.30	19.57	22.09	28.11	33.70	39.09
H2	16.18	16.18	18.19	20.24	24.76	27.91	36.30	43.94	51.18
ØD	7.20	7.20	9.96	9.96	12.05	12.05	13.98	17.52	17.52
A	0.63	0.63	0.63	0.63	0.63	0.63	0.75	0.75	0.75
B	0.31	0.31	0.31	0.37	0.37	0.37	0.43	0.50	0.50
ØD1	1.97	2.56	3.15	3.94	4.92	5.91	7.87	9.84	11.81
ØD2	2.24	2.71	3.33	4.32	5.39	6.44	8.43	10.55	12.52
ØD3	2.37	2.87	3.50	4.50	5.56	6.63	8.63	10.75	12.75



Stock No. 1010201

UL and cUL Listed, FM Approved, CSFM Listed, NYMEA Accepted

Dimensions: 7" L x 3.75" W x 3" D (including bracket)
(17,7 cm x 9,5 cm x 7,6 cm)

Weight: 13.6 oz. (385,5 g.)

Enclosure: Non-Corrosive Composite Material

Environmental Limitations:

- NEMA 4 and NEMA 6P rated enclosure when proper electrical fittings are used. (IP67)
- Temperature range: -40° F to 140° F (-40° C to 60° C)

Housing Cover Tamper: Activated by housing cover removal.

Contact Ratings: SPDT Plug Contacts: 100 mA at 28 VDC/AC
250 mA at 12 VDC/AC
SPDT Cover Tamper: 250 mA at 28 VDC/AC

Cable: 2-wire, 18 Ga. Waterproof - Approx. 8' (2,43m) long

General

The Model PTS-C is designed to supervise sprinkler system control valves and may also be used to secure gates and other applications. This unit is particularly useful for unusual conditions, such as non-rising stem valves.

Nema 6P enclosure allows the device to be mounted outdoors, even in areas subject to flooding such as pits and wells. Sealed reed switch operation virtually eliminates contact corrosion.

Turning the valve wheel will pull the plug out of the receptacle. The plug cannot be reinserted after operation until the plug receptacle cover is removed with the special hex key provided. This key should be left with the building owner or responsible party. Replacement or additional cover tamper screws and hex keys are available. For cover tamper screws, order stock no. 5490344. For hex key, order stock no. 5250062.

Installation

Insert plug into housing, take the loose end of the cable and loop it through the valve handle and into the housing. Adjust the length of cable so the plug must be pulled from the housing when the valve is closed. Cut off excess cable and terminate on the plug terminals of the PC board. Do not leave more than 2" (50mm) of excess wiring in the housing. Dress wires to outside edge of housing so as not to interfere with cover tamper.

Wire Checkout

With the plug wired to the two P terminals and the plug inserted fully into the receptacle, place an ohmmeter across the C and N.O. terminals. The meter will show Open. Unplug the plug from the receptacle. The meter will show continuity.

Note: The two P terminals will always show continuity when the plug is connected regardless of whether the plug is inserted or not.

The cover tamper switch can be wired into the plug circuit or wired as a separate circuit. (See wiring diagrams.)

Testing

The PTS-C and its associated protective monitoring system should be tested in accordance with applicable NFPA codes and standards and/or the authority having jurisdiction (manufacturer recommends quarterly or more frequently).



WARNING

As Stipulated By Factory Mutual And Underwriters Laboratories

This unit is not intended or designed for ordinary use. It is a special application device to be used for unusual conditions such as non-rising stem gate valves where no other approved or listed method of protection is available or practical. As this unit does not meet NFPA codes and standards, requiring restoration signal when the valve is positioned to normal, special attention should be given by the responsible parties to assure that the proper operation of this device is maintained. This device should only be restored to normal when the valve is in the normal condition.

Installation Instructions

Description

TrimFit® Model BFT (Threaded Butterfly Valve) and Model BFG (Grooved Butterfly Valve) close slowly to prevent water hammer. The butterfly valves are designed to be installed in any orientation and monitored to signal if the valve is opened or closed. They are Listed and Approved for use in a fire sprinkler system.



Installation

1. The valve can be installed in any orientation in a piping system with standard ASME B1.20.1 NPT or standard roll or cut grooved pipe.
2. When threading to pipe, apply PipeFit® or equivalent thread sealant or tape.
3. Use a wrench to cramp on the hexagon end of the valve.
4. The tamper switch features two switches: Switch-1 has dual leads on the terminals. This switch is used for connection of the supervisory circuit of a listed fire alarm control panel. Switch-2 has a single lead. This switch is used for connection of auxiliary equipment.
5. All the unused wires need to be capped with lead nuts and tucked into a junction box.
6. All connections need to be reviewed and approved by the appropriate jurisdictional authorities.

7. A No. 14 green wire is fixed inside the switch housing. It is provided as a ground for the housing.
8. The valves are intended for use with ANSI B36.10 Schedule 40 and/or Schedule 80 pipes, sizes 1", 1-¼", 1-½", 2" and 2-½".

NOTE: ALL REPLACEMENT PARTS MUST BE OBTAINED FROM THE MANUFACTURER TO ASSURE PROPER OPERATION OF THE VALVE, AND TO MAINTAIN APPROVAL OF THE DEVICE.

The information contained herein is produced in good faith and is believed to be reliable but is provided for guidance and information purposes only. FPPI and its agents cannot assume liability or responsibility for results obtained in the use or misuse of its product by persons whose methods and qualifications are outside and beyond our control. It is the user's responsibility to determine the suitability of, methods of use, preparation prior to use, and appropriate installation for all products purchased from FPPI. It is the user's sole responsibility to observe and adapt such precautions as may be advisable or necessary for the protection of personnel and property in the handling and use of any of our products.

Specifications

Rated to 300 PSI
Switch rating:
10.1Amps/125/250VAC-60Hz
Actual switch application rating:
10 Amps/115 VAC-60Hz
0.5 Amps/28 VDC
Indoor/Outdoor Use

Materials

Body: Bronze ASTM 584 C83600
Disc: SS304
Handwheel: ASTM A216 WCB
Seat: ASTM D2000 Viton
Indicator: Powder Metal
Housing/Cover: Forged Brass
JIS C3771 (Ref. ASTM C37700)

Available Sizes

TrimFit® Model BFT (Threaded)
06-500-00 1" UL/FM
06-502-00 1¼" UL/ULc/FM
06-504-00 1½" UL/ULc/FM
06-506-00 2" UL/ULc/FM
06-508-00 2½" UL/ULc/FM

TrimFit® Model BFG (Grooved)
06-522-00 1¼" UL/ULc/FM
06-524-00 1½" UL/ULc/FM
06-526-00 2" UL/ULc/FM
06-528-00 2½" UL/ULc/FM

CA Bldg. Materials Listing #
7770-2164-0100



3198 LIONSHEAD AVE
CARLSBAD, CA 92010
+ 1 (760) 599-1168
+ 1 (800) 344-1822
+ 1 (800) 344-3775 FAX

© 2016 Fire Protection Products, Inc.



Valve Handle Lockout Covers

1.	Product Number Modèle n° Modelo Núm.	For Valve Handle Diameters Diamètre du volant de manœuvre Para diámetros de manija de válvula
	480	1 in.- 3 in. (25 mm - 76 mm)
	481	2 in.- 5 in. (51 mm - 12.7 cm)
	482	4 in.- 6.5 in. (10.2 cm - 16.5 cm)
	483	6 in.- 10 in. (15.2 cm - 25.4 cm)
	484	8 in.- 13 in. (20.3 cm - 33 cm)

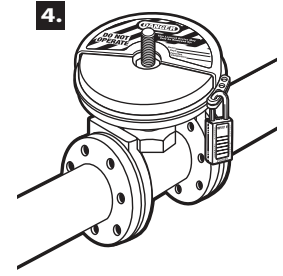
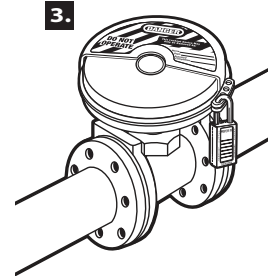
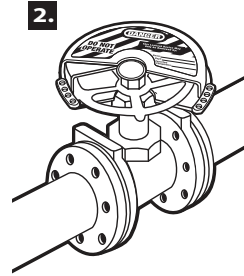

Assembly Instructions

1. Select the properly-sized cover for the specific valve handle to be locked out. Note: Cover should be loose enough when applied that it does not bind to the valve handle.
2. Rotate the lockout cover to completely surround the valve handle (Illustration 2).
3. Secure with Master Lock safety lockout padlock(s) by inserting shackle(s) through the overlapping locking eyelets (Illustration 3).
4. To secure a valve handle which has a rising stem, cut out the circular center section of the lockout cover (Illustration 4).

One "Valve Handle Lockout Cover" or equivalent, shall be provided; to be used in accordance with NFPA 20, sections 4.17.1 (3) & 4.17.2.



www.masterlocksafety.com • www.masterlock.com

© 2015 Master Lock Company LLC | All Rights Reserved

Master Lock Company LLC, Milwaukee, WI 53210 U.S.A. | 800-308-9244

Master Lock Canada Inc., Mississauga, Ontario L5L 5Z9 | (800) 227-9599 | Fax: (800) 229-0081

Master Lock Europe, 92200 Neuilly-sur-Seine, France, 00 33 1 41 43 72 00, E-mail: safety@master-lock.fr

Master Lock Europe-UK Office, Wakes Colne, Colchester CO6 2DB, UK, 0044,1,787,222,027, E-mail: safetyeu@mllock.com

玛斯特锁贸易(上海)有限公司 上海市浦东新区银城中路168号上海银行大厦1006室 400-820-6535 E-mail:safetychina@mllock.com

Check Valves

UL LISTED AND FM APPROVED

WWW.FPPI.COM



3198 LIONSHEAD AVE
CARLSBAD, CA 92010
+ 1 (760) 599-1168
+ 1 (800) 344-1822
+ 1 (800) 344-3775 FAX

LISTED VALVE NOW
AVAILABLE IN
1 1/2" SIZE



- Brass Body* (C38000) for superior corrosion resistance
- Listed valves available in the following sizes: 1 1/2"**, 2", 2 1/2", 3" and 4"
- Available Grooved, Threaded, or Thread by Groove reducing the need for additional fittings and minimizing installation time.
- Pressure rated to up to 300 PSI
- Tapped and plugged for easy use of accessories such as ball drips or gauges



*Contains lead. Not for use in water systems intended for human consumption.

**1 1/2" size is UL/ULc listed only



NFPA20 Sensing Line Detail

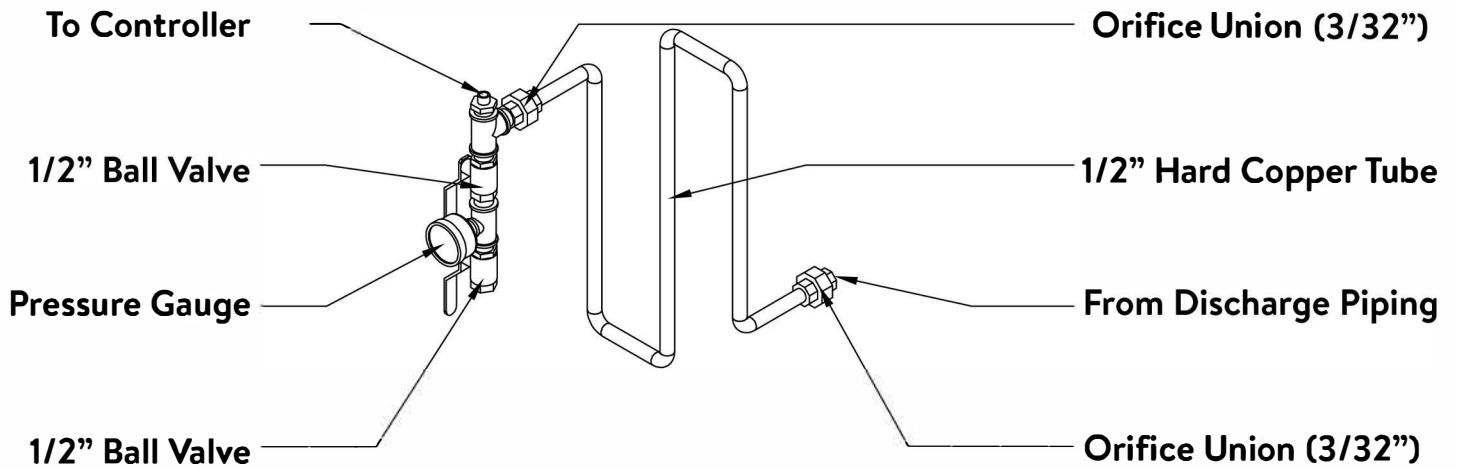

Pressure Sensing Lines constructed in accordance with NFPA 20:
All brass or copper components, orifice unions at connections to
both discharge piping & controller valve assembly, minimum 60"
hard copper tubing between unions.