

# HOME HYDRANT

FOR POTABLE WATER SYSTEMS

NFPA-13D Packaged Residential Fire Pump & Tank

U.S. Patents #8,678,032 & 8,905,069

## HH3-PW

Included with Potable Water Systems -

(1) Home Hydrant Tank and Stainless Steel Pump

(1) PW Safe Discharge Manifold (no flow switch included)

### 350 Gallon Water Tank

- ① Tank Drain 1/2"(GHT)
- ② Overflow Fitting 1"(FNPT)
- ③ Auto-Fill Valve 3/4"(FNPT)

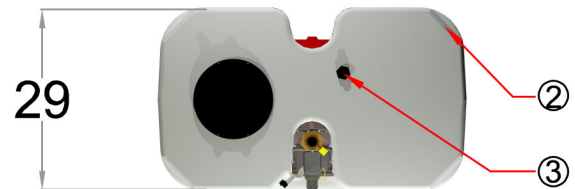

3HP Electric Motor  
240 Volt Single-Phase  
13 Amp (Full Load)

### 1 1/4" Discharge (FNPT) Stainless Steel *Smart Riser*

- ④ Isolation Ball Valve
- ⑤ Pressure Switch
- ⑥ Pressure Gauge
- ⑦ Test Line/System Drain
- ⑧ Run-Time Controller
- ⑨ Discharge Check Valve
- ⑩ Suction Shut-off Valve

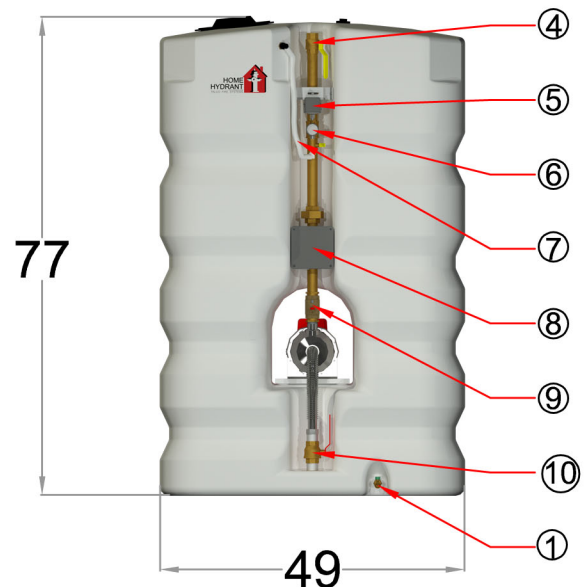

## Pump Performance

All dimensions inches.

Performance values based on multiple pump tests. Not for certification purposes.

GPM	0	25	30	35	40	45	50	55
PSI	59	57	55	54	53	51	50	49