

HOME HYDRANT

FOR POTABLE WATER SYSTEMS

NFPA-13D Packaged Residential Fire Pump & Tank

U.S. Patents #8,678,032 & 8,905,069

HH2-PW

Included with Potable Water Systems -

(1) Home Hydrant Tank and Stainless Steel Pump

(1) PW Safe Discharge Manifold (no flow switch included)

250 Gallon Water Tank

- ① Tank Drain $\frac{1}{2}$ "(GHT)
- ② Overflow Fitting 1"(FNPT)
- ③ Auto-Fill Valve $\frac{3}{4}$ "(FNPT)
- ④ 85 Gallon Bladder Tank

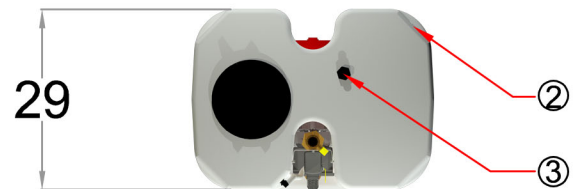

3HP Electric Motor

240 Volt Single-Phase

13 Amp (Full Load)

1 $\frac{1}{4}$ " Discharge (FNPT)

Stainless Steel *Smart Riser*

- ⑤ Isolation Ball Valve
- ⑥ Pressure Switch
- ⑦ Pressure Gauge
- ⑧ Test Line/System Drain
- ⑨ Run-Time Controller
- ⑩ Discharge Check Valve
- ⑪ Suction Shut-off Valve

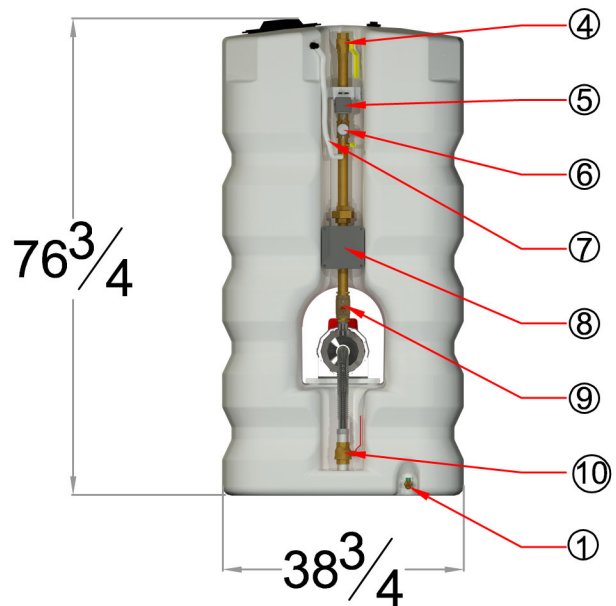

Pump Performance

All dimensions inches.

Performance values based on multiple pump tests. Not for certification purposes.

GPM	0	25	30	35	40	45	50	55
PSI	59	57	55	54	53	51	50	49