

FTS-300A

NFPA-13D Residential Package

Maximum Suction Pressure: 45PSI

System Specifications

Motor

- 3 Horsepower Electric
- 240 Volt, 14.2 Amp
- Single Phase
- 3450

Pump

- 316 Series Stainless Steel Volute
- Stainless Steel Impeller
- 1 1/4" Suction
- 1 1/4" Discharge
- 125 PSI Max Working Pressure

Controls

- 240 Volt
- Minimum Run Timer
- Contactor
- HOA Toggle Switch (Hand, Off, Auto)

Dimensions (Approximate)

- 20" Length
- 20" Height
- 12" Width
- 81 Pounds

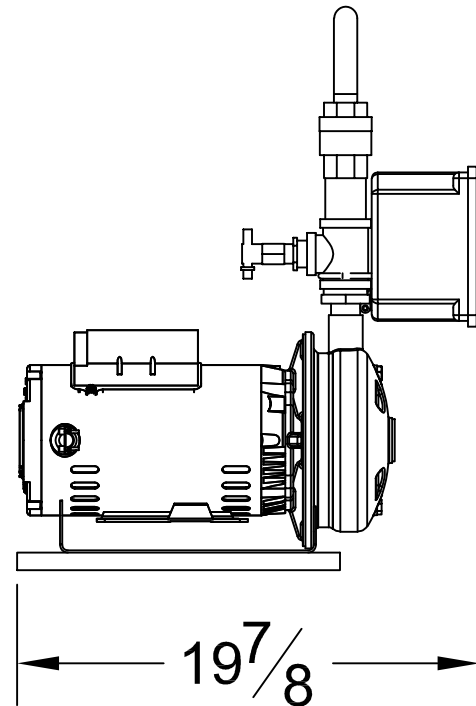
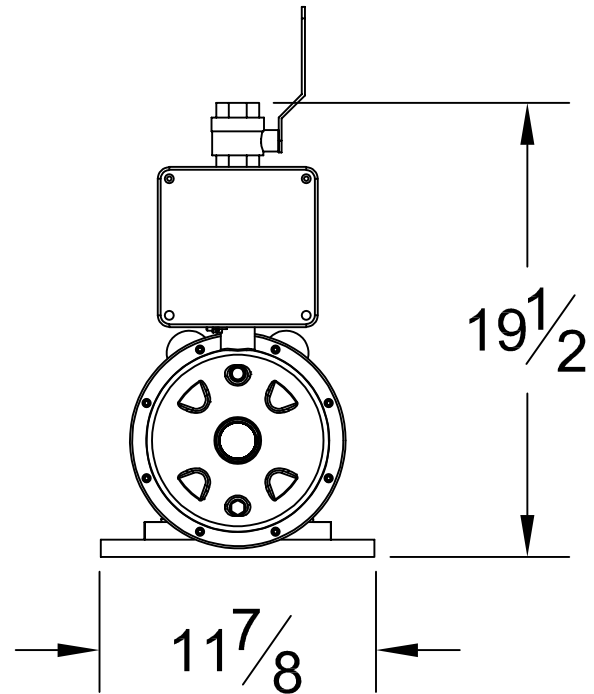

Performance

Performance values based on multiple pump tests. Not for certification purposes.

GPM	0	30	35	40	45	50	55	60
PSI	77	58	54	49	47	43	39	35