

## LSF-500CIF

NFPA-13D Residential Package

Maximum Suction Pressure: 72PSI

### System Specifications

#### Motor

- 5 horsepower electric
- 240 Volt, 21.5 Amp
- Single Phase
- 3450 RPM

#### Pump

- High pressure cast iron volute
- Machined bronze impeller
- 1½" Suction
- 1¼" Discharge
- 150 PSI Max Working Pressure

#### Discharge Manifold

- Check Valve
- Zero to 100 PSI pressure gauge
- 40/60 pressure switch
- Isolation ball valve

#### Controls

- 240 Volt
- Minimum run timer
- Pressure switch operated contactor
- HOA toggle switch (Hand, Off, Auto)

#### Dimensions (approximate)

- 22<sup>7</sup>/<sub>16</sub>" Length
- 19<sup>1</sup>/<sub>2</sub>" Height
- 14" Width
- 135 pounds

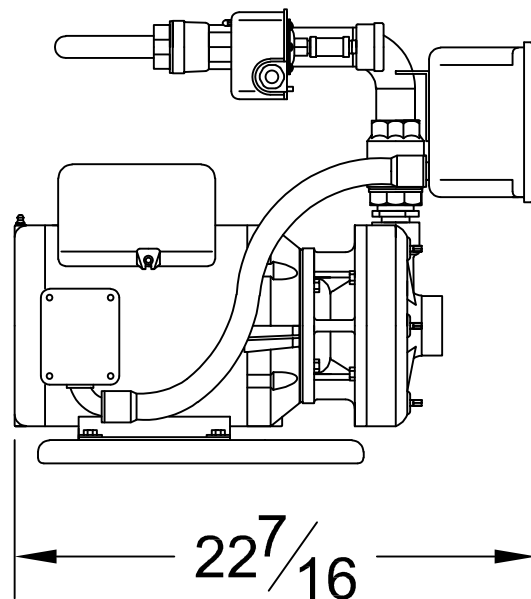
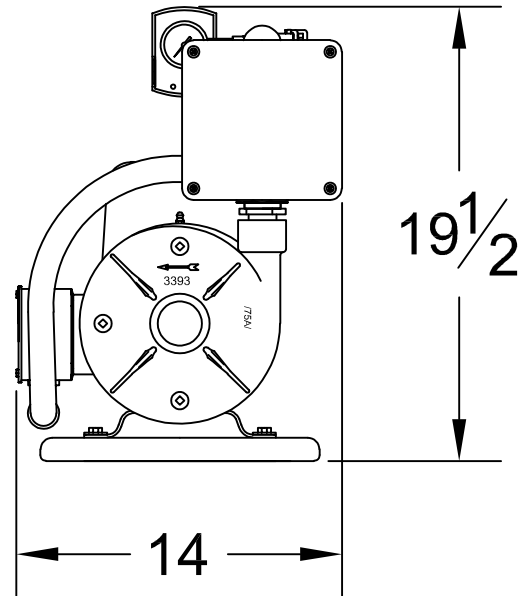

## Performance

Performance values based on multiple pump tests. Not for certification purposes.

GPM	0	35	40	45	50	55	60	65
PSI	75	71	70	69	67	66	64	60