

Residential Packaged Fire Pump System

HDR-75

Heavy Duty Residential Package
 Design Condition: 75GPM @ 65PSI

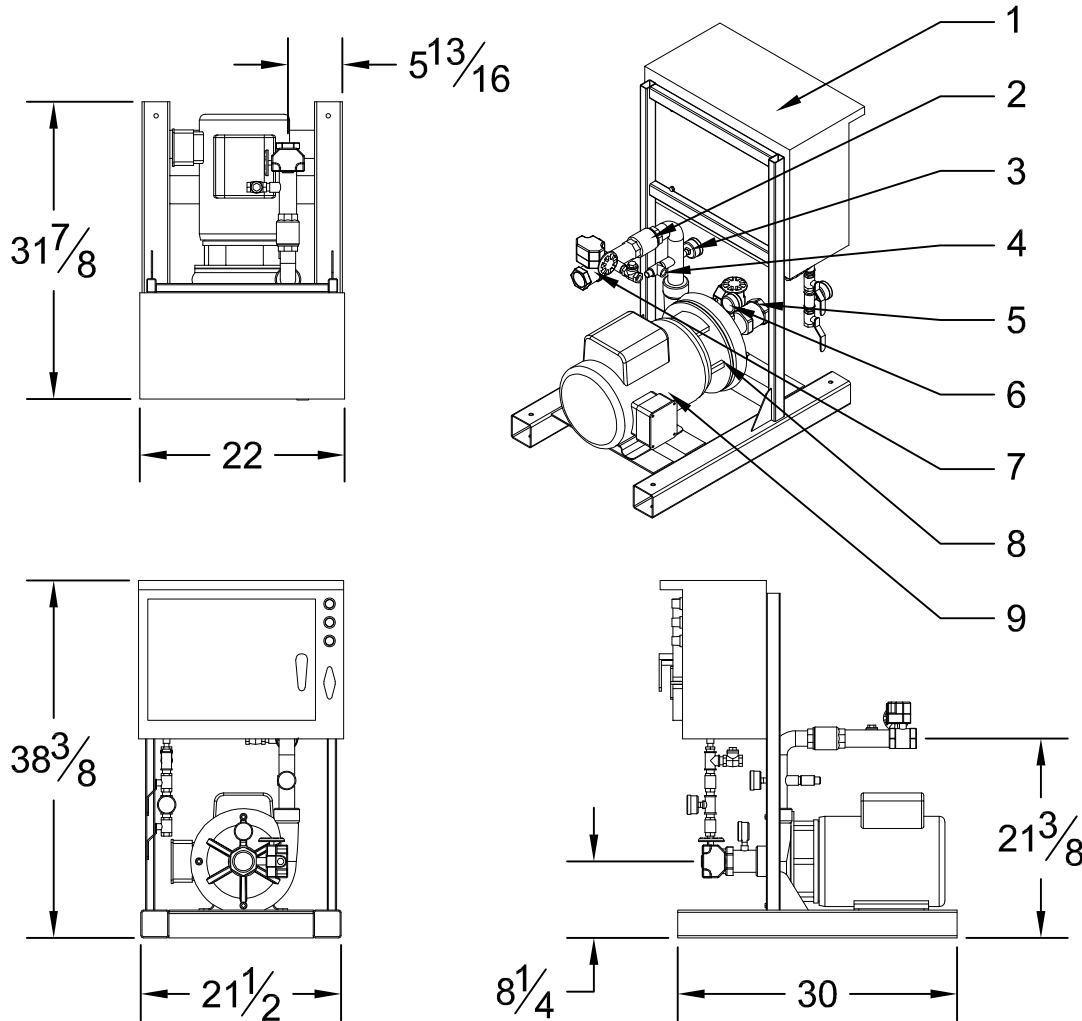

System Specifications:

Motor
 -7.5 Horsepower Electric
 -230 Volt
 -37 Amp
 -Single Phase
 -3450 RPM

Pump
 -End Suction Centrifugal Pump
 -2" Suction (NPT)
 -1 1/2" Discharge (NPT)
 -175 PSI max working pressure

System Components
 -1- Residential Fire Pump Controller
 -2- Check Valve
 -3- Discharge Pressure Gauge
 -4- Case Relief Valve
 -5- Suction Monitored Butterfly Valve
 -6- Suction Pressure Gauge
 -7- Discharge Monitored Butterfly Valve
 -8- End Suction Pump
 -9- Electric Motor
 -Not Shown- Copper Sensing Line (per NFPA20)

Performance

Performance values based on multiple pump tests. Not for certification purposes.

GPM	0	65	75	85	95	105	115	125
PSI	73	67	65	62	59	55	53	50

Please Note: This fire pump system uses an unlisted pump & a residential controller. Please submit to your AHJ for approval prior to ordering.