

Residential Packaged Fire Pump System

HDR-50

Heavy Duty Residential Package
Design Condition: 50GPM @ 65PSI

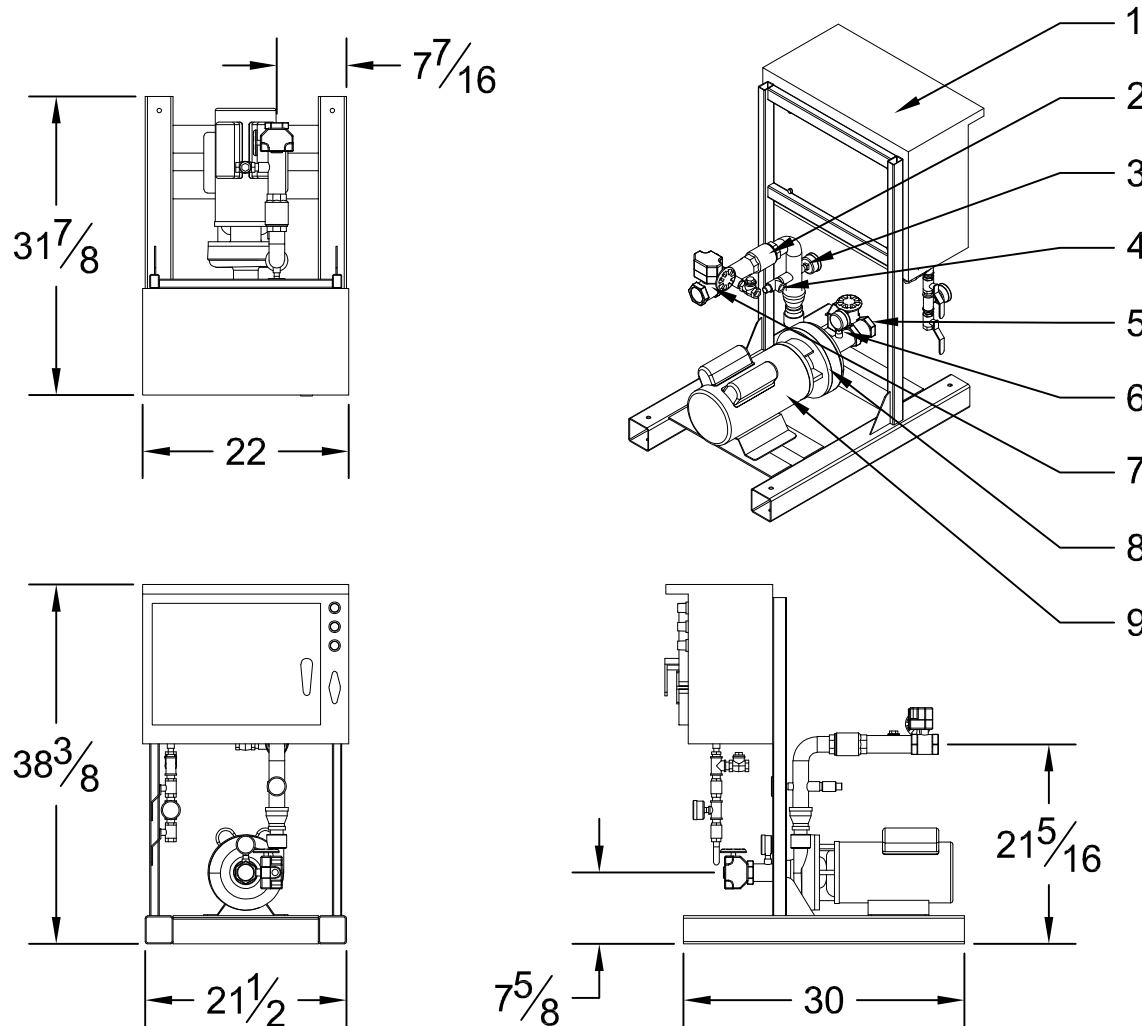

System Specifications:

Motor

- 5 Horsepower Electric
- 230 Volt
- 21.5 Amp
- Single Phase
- 3450 RPM

Pump

- End Suction Centrifugal Pump
- 1 1/2" Suction (NPT)
- 1 1/2" Discharge (NPT)
- 175 PSI max working pressure

System Components

- 1- Residential Fire Pump Controller
- 2- Check Valve
- 3- Discharge Pressure Gauge
- 4- Case Relief Valve
- 5- Suction Monitored Butterfly Valve
- 6- Suction Pressure Gauge
- 7- Discharge Monitored Butterfly Valve
- 8- End Suction Pump
- 9- Electric Motor
- Not Shown- Copper Sensing Line (per NFPA20)

Performance

Performance values based on multiple pump tests. Not for certification purposes.

GPM	0	40	45	50	55	60	65	70	75
PSI	74	68	67	65	63	61	58	56	51

Please Note: This fire pump system uses an unlisted pump & a residential controller. Please submit to your AHJ for approval prior to ordering.