

NFPA13R Packaged Fire Pump System UL/FM Fire Pump

13-ULV50-R

Compact Residential Package
 Design Condition: 50GPM @ 60PSI

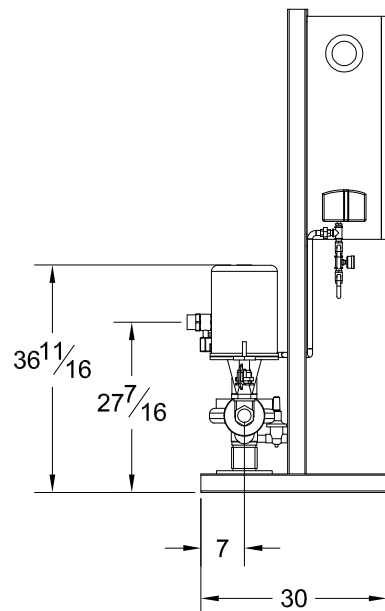
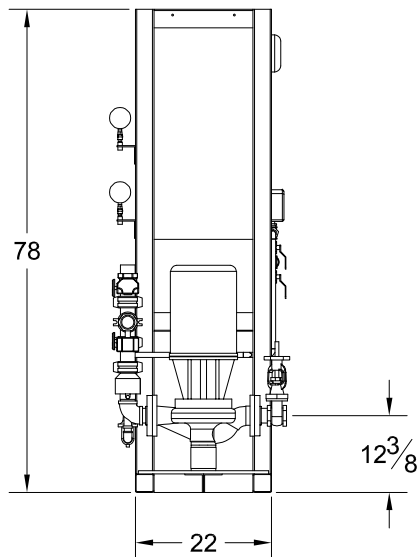
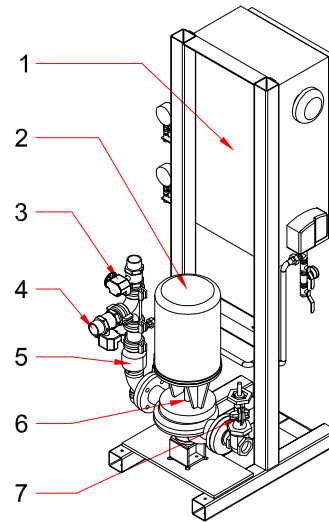
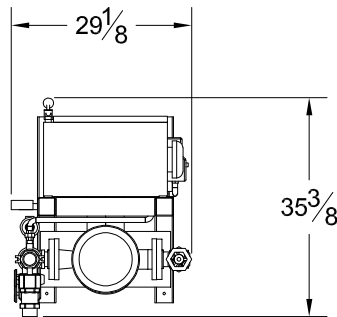

System Specifications:

- Motor
- 7.5 Horsepower Electric
- 230 Volt, 34.6 Amp
- Single Phase
- 3450 RPM

- Pump
- UL/FM Vertical Inline Fire Pump
- 2" Suction (FNPT)
- 2" Discharge (Grooved)
- 175 PSI max working pressure

System Components (UL Listed by Manufacturer)

- 1- Limited Service Fire Pump Controller
- 2- Electric Motor
- 3- Discharge Monitored Ball Valve
- 4- Test Connection Monitored Ball Valve
- 5- Check Valve
- 6- Vertical Inline Fire Pump
- 7- Suction OS&Y

(All Dimensions Are Approximate)

- 36" Depth
- 78" Height
- 32" Width