

NFPA13R Packaged Fire Pump System UL/FM Fire Pump

13-ULV100-R

Compact Residential Package
 Design Condition: 100GPM @ 75PSI

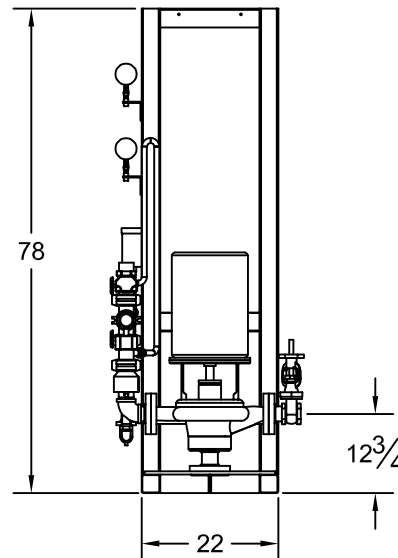
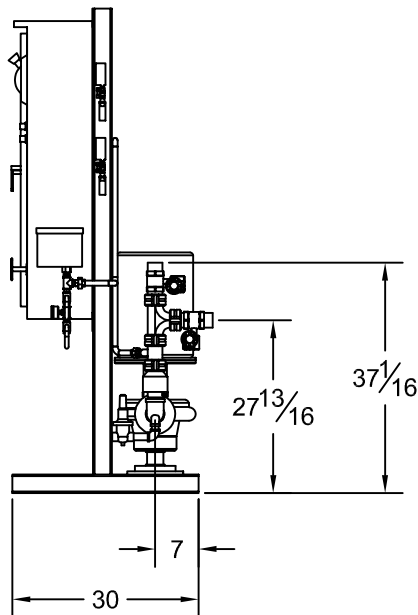
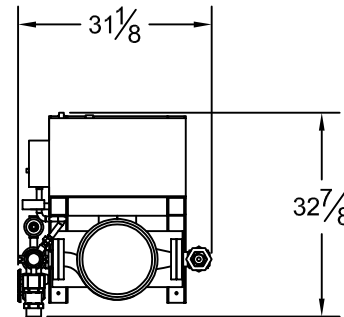
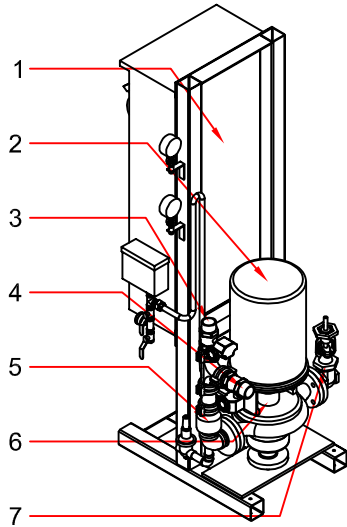

System Specifications:

- Motor**
- 10 Horsepower Electric
 - 230 Volt, 46 Amp
 - Single Phase
 - 3450 RPM

- Pump**
- UL/FM Vertical Inline Fire Pump
 - 2" Suction (FNPT)
 - 2" Discharge (Grooved)
 - 175 PSI max working pressure

System Components (UL Listed by Manufacturer)

- 1- Limited Service Fire Pump Controller
- 2- Electric Motor (UL Recognized)
- 3- Discharge Butterfly Valve (Monitored)
- 4- Test Connection Butterfly Valve (Monitored)
- 5- Check Valve
- 6- Vertical Inline Fire Pump
- 7- Suction OS&Y (Monitored)

Dimensions

- 33" Depth
- 78" Height
- 32" Width

*All dimensions are approximate and subject to change without notice.