

## UG-50

NFPA-13D Residential Underground  
Packaged Fire Pump System  
50GPM @ 75PSI

-3 HP 230V Single Phase  
-350# System Ship Weight

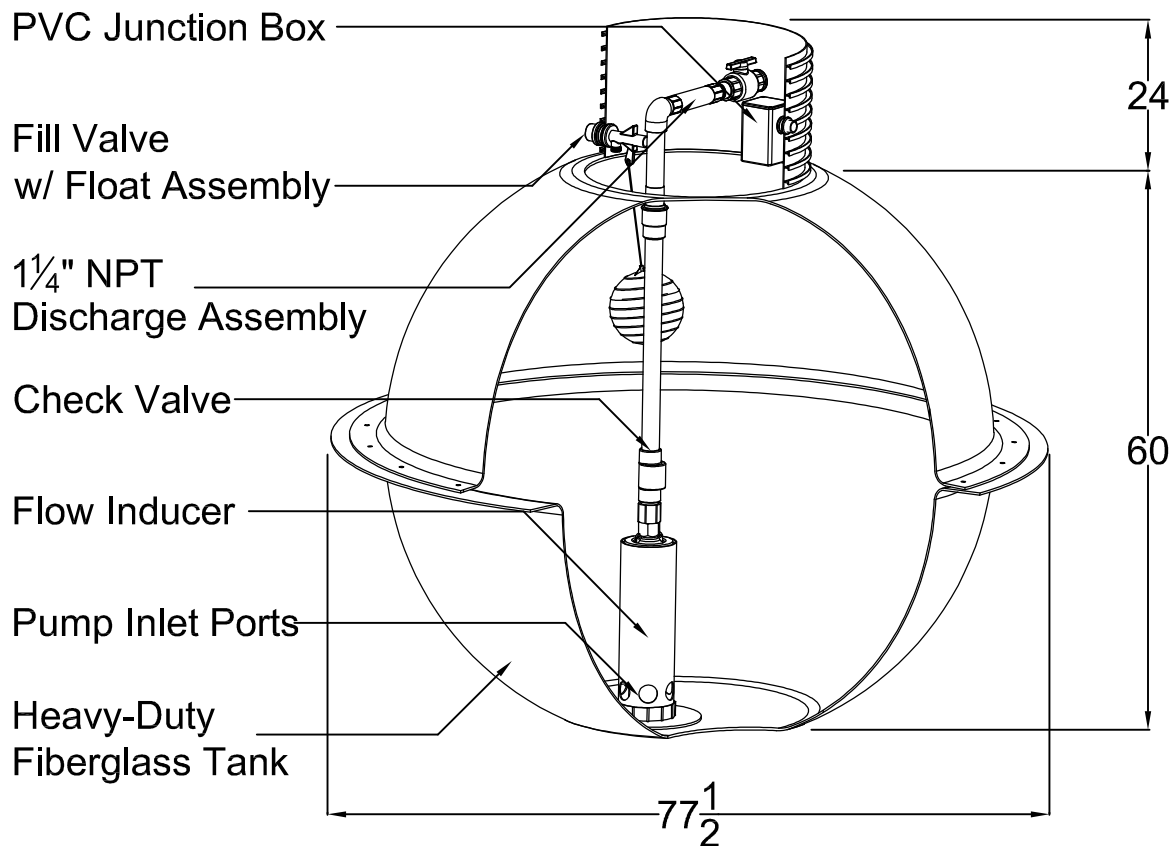
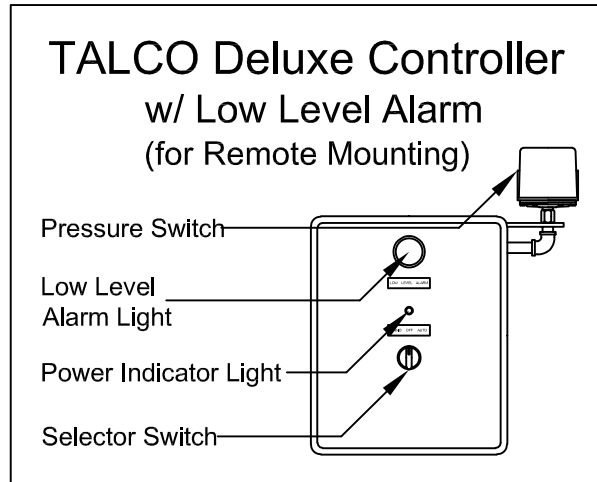

-All dimensions inches-