

## HOME HYDRANT

HOME HYDRANT - **FOR POTABLE WATER SYSTEMS**

NFPA-13D Packaged Residential Fire Pump & Tank

U.S. Patents #8,678,032 & 8,905,069

## HH4-PW

50GPM @ 50PSI

Included with Potable Water Systems -

(1) Home Hydrant Tank and Stainless Steel Pump

(1) PW Safe Discharge Manifold (no flow switch included)

450 Gallon Water Tank

- ① Tank Drain 1/2"(GHT)
- ② Overflow Fitting 1"(FNPT)
- ③ Auto-Fill Valve 3/4"(FNPT)



3HP Electric Motor  
240 Volt Single-Phase  
13 Amp (Full Load)

1 1/4" Discharge (FNPT)  
Stainless Steel *Smart Riser*

- ④ Isolation Ball Valve
- ⑤ Pressure Switch
- ⑥ Pressure Gauge
- ⑦ Test Line/System Drain
- ⑧ Discharge Check Valve
- ⑨ Suction Shut-off Valve

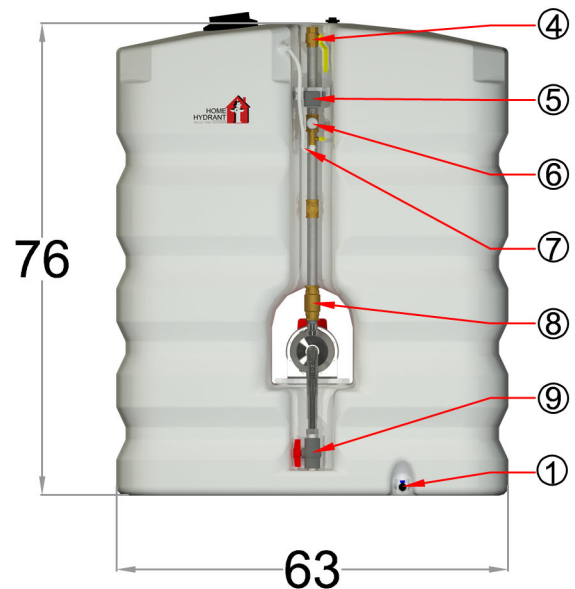

## Pump Performance

All dimensions inches.  
Performance values based on multiple pump tests. Not for certification purposes.

|     |    |    |    |    |    |    |    |    |
|-----|----|----|----|----|----|----|----|----|
| GPM | 0  | 25 | 30 | 35 | 40 | 45 | 50 | 55 |
| PSI | 59 | 57 | 55 | 54 | 53 | 51 | 50 | 49 |