

Residential Packaged Fire Pump System

HDR-50

Heavy Duty Residential Package
 Design Condition: 50GPM @ 65PSI

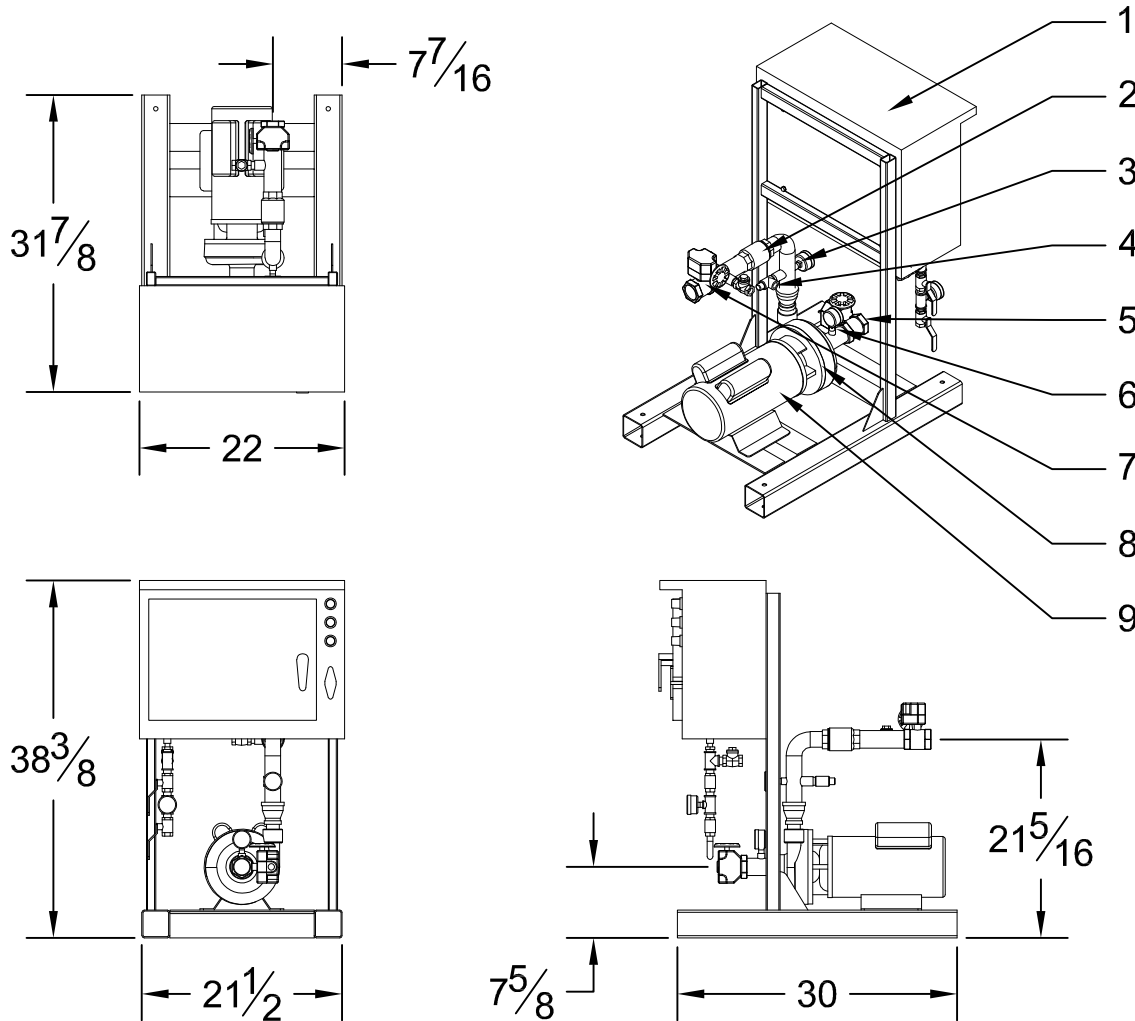

System Specifications:

Motor
 -5 Horsepower Electric
 -230 Volt
 -21.5 Amp
 -Single Phase
 -3450 RPM

Pump
 -End Suction Centrifugal Pump
 -1 1/2" Suction (NPT)
 -1 1/2" Discharge (NPT)
 -175 PSI max working pressure

System Components
 -1- Residential Fire Pump Controller
 -2- Check Valve
 -3- Discharge Pressure Gauge
 -4- Case Relief Valve
 -5- Suction Monitored Butterfly Valve
 -6- Suction Pressure Gauge
 -7- Discharge Monitored Butterfly Valve
 -8- End Suction Pump
 -9- Electric Motor
 -Not Shown- Copper Sensing Line (per NFPA20)

Performance

Performance values based on multiple pump tests. Not for certification purposes.

GPM	0	40	45	50	55	60	65	70	75
PSI	74	70	69	67	66	64	60	57	52

Please Note: This fire pump system uses an unlisted pump & a residential controller. Please submit to your AHJ for approval prior to ordering.