

FFX-30

NitroPower

Residential Fire Water Supply System

Low Maintenance

25 to 100 PSI Adjustable Pressure
30 GPM (Set for 10 minute run time)

System Components:

- Premium Brass Regulator
- Zero Leakage Relief Valve
- Nitrogen Gas Cylinder
- Fabricated Steel Water Pressure Tank (ASME Certified)
- Water Level Gauge
- Brass Check Valve
- Discharge Manifold & Fittings
- Mounting Hardware

Alarm Box:

- Audible Alarm
- Pressure Transducer
- 115 VAC (Required for alarm only)

Dimensions:

- Discharge Pipe Size: 1 $\frac{1}{4}$ " NPT
- Water Tank: 300 gallon
- 36" Diameter x 78" Tall
- Nitrogen Tank: 336ci.
- 11" Diameter x 62" Tall
- Pad Size: 54" x 54" (Recommended)
- Weight: 800# (Dry)

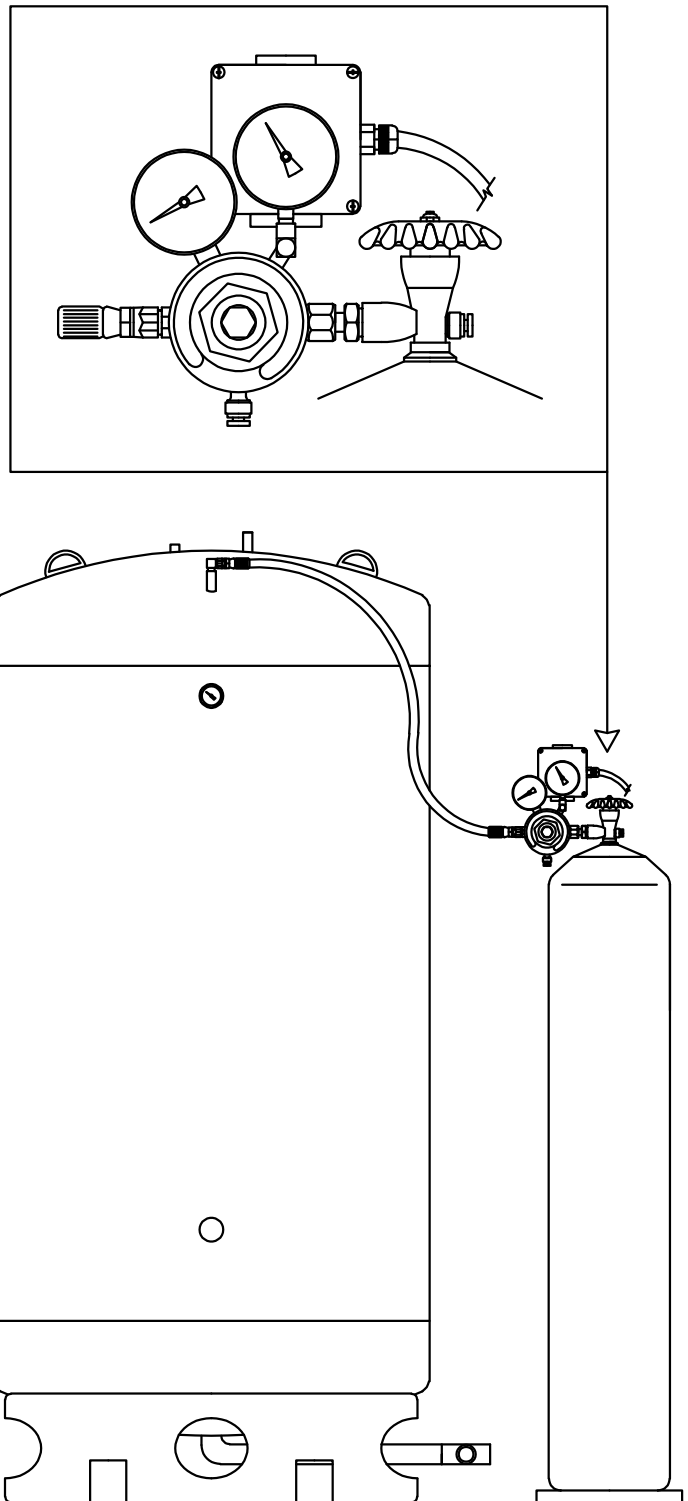

FFX-45

NitroPower

Residential Fire Water Supply System

Low Maintenance
No Power Required
25 to 100 PSI Adjustable Pressure
45 GPM (Set for 10 minute run time)

System Components:

- Premium Brass Regulator
- Zero Leakage Relief Valve
- Nitrogen Gas Cylinder
- Fabricated Steel Water Pressure Tank (ASME Certified)
- Water Level Gauge
- Brass Check Valve
- Discharge Manifold & Fittings
- Mounting Hardware

Dimensions:

- Discharge Pipe Size: 1 ¼" NPT
- Water Tank: 450 gallon
42" Diameter x 82" Tall
- Nitrogen Tank: 336ci. (Quantity - 2)
11" Diameter x 62" Tall
- Pad Size: 72" x 72" (Recomended)
- Weight: 1100# (Dry)

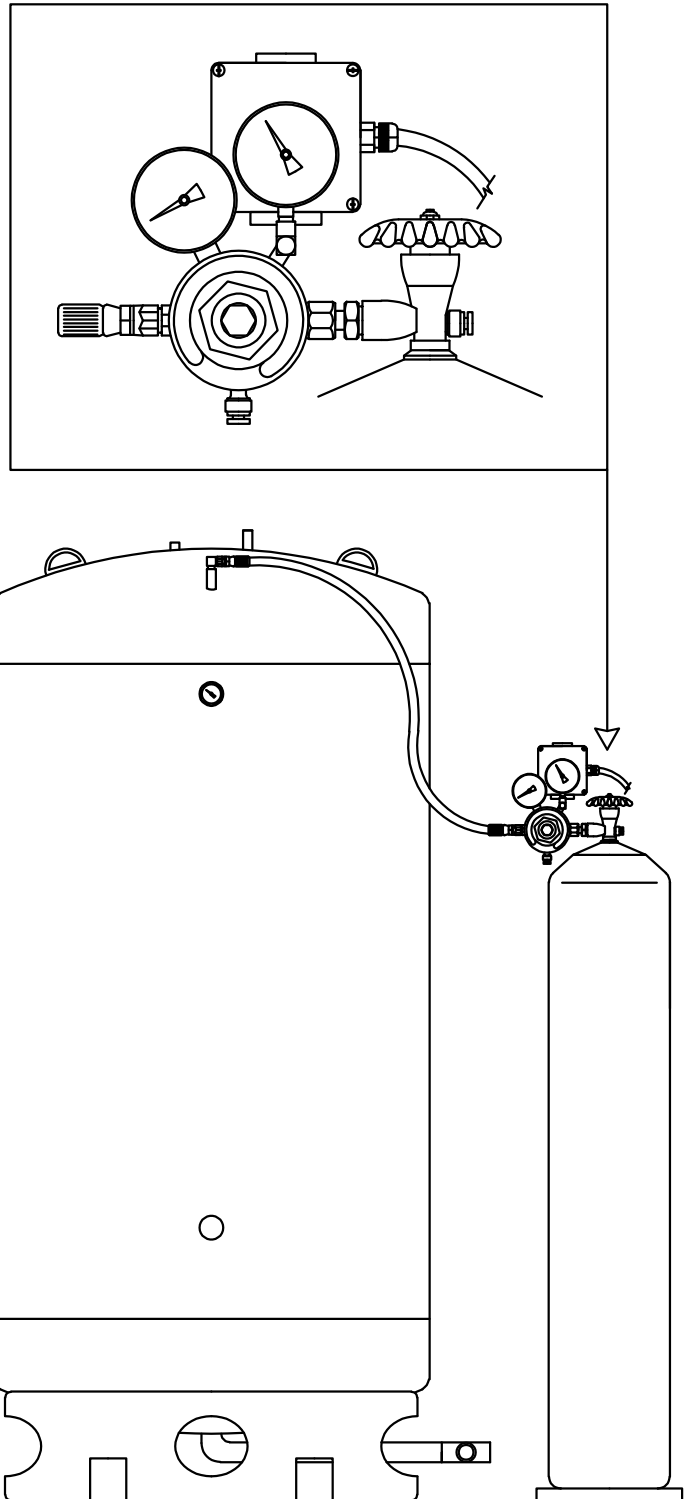

FFX-60

NitroPower

Residential Fire Water Supply System

Low Maintenance
No Power Required
25 to 100 PSI Adjustable Pressure
60 GPM (Set for 10 minute run time)

System Components:

- Premium Brass Regulator
- Zero Leakage Relief Valve
- Nitrogen Gas Cylinder
- Fabricated Steel Water Pressure Tank (ASME Certified)
- Water Level Gauge
- Brass Check Valve
- Discharge Manifold & Fittings
- Mounting Hardware

Dimensions:

- Discharge Pipe Size: 1 ¼" NPT
- Water Tank: 600 gallon
48" Diameter x 86" Tall
- Nitrogen Tank: 336ci. (Quantity - 2)
11" Diameter x 62" Tall
- Pad Size: 90" x 90" (Recomended)
- Weight: 1400# (Dry)

