



Portland, OR
(503) 688-1231 / (503) 688-1234(FAX)

HDR

**Heavy Duty Residential
Fire Pump Package**

O&M Start-Up Manual

TALCO FIRE SYSTEMS

HDR Start-Up Instructions

- 1) **IMPORTANT!** Inspect the unit for damage. Report any damage to the freight carrier immediately. START UP TESTING MUST BE PERFORMED BY QUALIFIED PERSONNEL.
- 2) **PRE-START-UP:** Be sure there is water in the pump. Bleed air from the top plug on the pump casing. Open the ball valves on the sensing line gauge assembly until air is bled. If possible, allow water to flow through the pump and system drain.
- 3) **INITIAL START-UP:** After completing step #2, close the discharge valve and turn the pump on by closing the 'Circuit Breaker Disconnecting Means' breaker on the front of the controller. An alarm will sound and the red "pump run" light should be lit. Observe the discharge pressure gauge. If the pump fails to rapidly build pressure, makes excessive noise, or vibrates turn it off immediately and see the O&M "Troubleshooting" section for help. If the pump operates smoothly allow it to run until the 10 minute minimum-run timer cycles the system off.
ADJUST THE CASING RELIEF VALVE UNTIL A MINIMUM FLOW OF 3 GPM IS DISCHARGED TO A SAFE DRAIN LOCATION. FAILURE TO DO THIS WILL CAUSE MAJOR DAMAGE TO THE PUMP.
Note the system pressure indicated on the discharge pressure gauge. Now slowly open the discharge ball valve, allowing the pump to restart and slowly fill the system. Once the system is charged to the pressure noted earlier and the pump cycles off, fully open the discharge ball valve. The system is now ready for normal operation.
- 4) **COMMISSIONING TEST:** The pump must now be started 6 times via the manual start push button. Allow a minimum of 10 minutes run time after each start and then stop the pump using the manual stop push button. The pump must also be started 6 times by opening the system drain until the pump starts automatically. The pump must be allowed to run a minimum of three minutes after each start. During this test record discharge pressure, motor amps, and flow at zero, 100%, and 150% of design flow. Maintain a dated record of the start up report. If any deficiencies are discovered during this test correct them and re-test the system.

- 5) PRESSURE TRANSDUCER ADJUSTMENT: The cut-in cut-out settings for the transducer may need to be adjusted in order to work with the system's specific design conditions. In the event this is required see controller manufacturer's O&M.
- 6) PERIODIC TESTING: The system can be tested at any time by slowly opening the system drain until the pump starts. After the pump starts slowly close the system drain and observe the maximum pressure and verify that the system stops automatically after the 10 minute minimum-run timer expires.

TALCO FIRE SYSTEMS

HDR Troubleshooting

1) PUMP WON'T START:

A) Check incoming power. Check the circuit breakers feeding the pump and reset as necessary.

B) Check for motor overload. Compare running motor amps to the values noted on the shop test report. If the overload condition is present check for low input voltage or foreign material binding the pump. Motor overloads may have tripped and will need to cool in order to reset. Determine and correct cause of overload.

C) Push in emergency start button. If pump runs in emergency start but does not run automatically then either; (1) The transducer cut-in pressure is set too low and needs to be raised. (2) There is a problem with the transducer. Take corrective action as necessary.

2) MOTOR RUNS BUT MAKES NOISE:

A) Check for debris in the pump.

B) Check to make sure there is adequate water from the supply.

C) The motor bearings may be worn. This needs to be remedied by a qualified technician.

3) PUMP CONTINUES TO RUN:

A) The transducer cut-out is set too high.

B) Suction pressure has dropped.

4) PUMP CYCLES RAPIDLY:

A) Check valve is fouled.

B) There is a leak in the system.

C) Minimum-run timer is inoperative.

TALCO 13R-C AND ULV FIRE PUMP SYSTEM START UP REPORT AND WARRANTY REGISTRATION

Date:		Installing Contractor
Project Name		Contractor Address
Project Address		Phone#
Contact & Phone#		Tested By

Model #	PUMP DATA:	CONTROLLER	JOCKEY PUMP:
Serial #			

SYSTEM INFORMATION AND START UP CHECK LIST

Static Supply Pressure	# Manual Starts: (Minimum 6)	Alarms connected and attended?
Suction Pipe Size	# Auto Starts: (Minimum 6)	Verify pump run alarm
Length of suction piping	System run minimum of 1 hour?	Verify power available alarm
# of elbows in suction piping	Pump operates on emergency start handle?	Verify suction valve tamper alarm
Electrical supply voltage	Owner instructed in operation and weekly testing in accordance with NFPA-25?	Verify discharge valve tamper alarm

Static Suction Pressure:	Psi	Jockey Start Pressure:	Psi	Min Run Time:	Min.
System Start Pressure:	Psi	Jockey Stop Pressure:	Psi	Verify MRT operation	
System Stop Pressure:	Psi				

FIELD TEST RESULTS: (See Below) NOZZLE SIZE:

Flow	GPM	Suction Pressure	Discharge Pressure	Net. psi	Pitot Readings	Amps	Volts
0	0						
100%							
150%							

FIELD TESTING MUST BE CONDUCTION IN ACCORDANCE WITH NFPA-20 GUIDELINES. TO VALIDATE

WARRANTY COMPLETED FORM MUST BE FAXED TO TALCO FIRE SYSTEMS (503) 688-1234

WIRING DIAGRAM

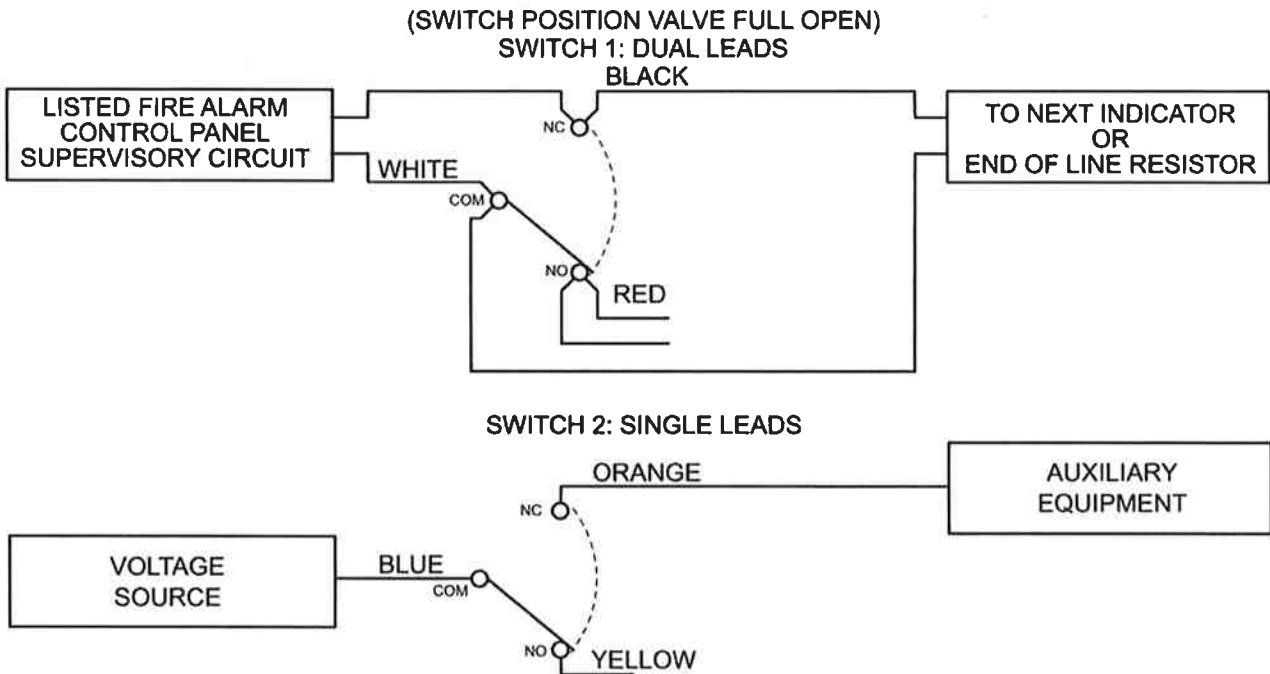

Green Lead provided is ground for switch housing

Switch Rating: 10AMP/ 115 VAC
.5 AMP/28 VDC

Cap unused leads with wire nuts and tuck inside junction box (not provided)

NOTE: Valves incorporating supervisory tamper switches are for **indoor use only**.

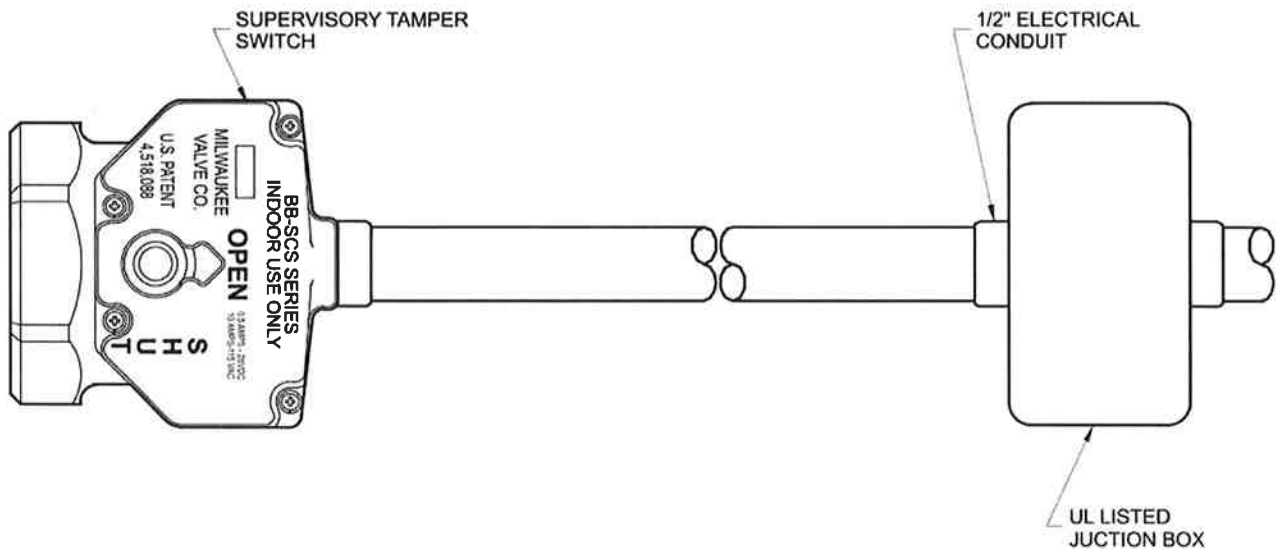

Milwaukee Valve Company
2375 South Burrell Street
Milwaukee, Wisconsin 53207-1592
Telephone 414/744-5240
FAX 414/744-5840



TALCO FIRE SYSTEMS

Limited Warranty

All goods are warranted to be free of defects in material and workmanship for a period of one year from start-up or (18) months from the date of shipment, whichever comes first. Except as specifically indicated, TALCO makes no warranties, expressed or implied, oral or written, including, but not limited to, any implied warranty of merchantability or fitness for a particular purpose.

THIS WARRANTY IS SPECIFICALLY SUBJECT TO THE FOLLOWING:

1. The limited warranty is limited to replacement or repair of defective materials and workmanship at the discretion of TALCO.
2. Equipment sold, but not manufactured by TALCO, is subject to the manufacturer's warranty only. TALCO makes no warranties, either expressed or implied, for goods manufactured by others.
3. The limited warranty is conditioned on the purchaser giving TALCO notice within five days of discovery of any alleged defect. Notice should be directed to TALCO FIRE SYSTEMS, by mail: 6040 NE 112th Ave, Portland OR, 97220; by fax: (503) 688-1234; or via E-mail: admin@talcofire.com.
4. The limited warranty shall be considered null and void if any product or part of the packaged system has been repaired or altered in any way by others without prior authorization from TALCO. Fitting leaks and electrical damage are considered the responsibility of the installing contractor.
5. TALCO shall not be liable for any incidental or consequential loss, damage or expense arising directly or indirectly from the use of any goods subject to this limited warranty, nor shall TALCO be liable for any damages or charges for labor or expense in making repairs or adjustments to the goods. TALCO shall not be liable for any damages or charges sustained in the adaptation or use of its engineering data or services.
6. This warranty shall not apply to any goods subject to misuse due to common negligence or accident, nor to any goods manufactured by TALCO which are not operated in accordance with TALCO printed instructions.
7. The liability of TALCO is limited to material replacements FOB Portland, Oregon.
8. All shipments are FOB TALCO dock and it will be the responsibility of the purchaser to check the goods when they are received and report to the Freight Company any damage that might have occurred.

MAIN FIRE PUMP CONTROLLER

TALCO  **FIRE SYSTEMS**

6040 NE 112th Ave. Portland, Oregon 97220

Phone: (503) 688-1231 Fax: (503) 688-1234

Instructions for Cutler-Hammer Residential Electric Fire Pump Controllers



Table Of Contents

1. INSTALLATION AND MOUNTING OF THE CONTROLLER.....	1
2. SYSTEM PRESSURE CONNECTIONS	1
3. ELECTRICAL CONNECTIONS.....	1
3.1 WIRE SIZES.....	1
3.2 ELECTRICAL CHECKOUT INSTRUCTIONS.....	2
3.3 PRESSURE SWITCH SETTING INSTRUCTIONS.....	3
3.4 CIRCUIT BREAKER.....	3
3.5 EMERGENCY HANDLE	3
3.6 CONTACTOR.....	3
3.7 PILOT DEVICES.....	4
3.8 PRESSURE SWITCH	4
3.9 REMOTE START / MANUAL START RELAY	4
3.12 LOW SUCTION (OPTION)	4
4. OPERATION OF THE CONTROLLER.....	4
4.1 SEMI-AUTOMATIC OR AUTOMATIC OPERATION	4
4.2 RUNNING PERIOD TIMER	4
4.3 SEQUENTIAL START TIMER (OPTION).....	5
5. FIGURE 1: TYPICAL SCHEMATIC	6
6. FIGURE 2: DIMENSIONAL DRAWING.....	7

INSTALLATION & MAINTENANCE MANUAL FOR THE RESIDENTIAL ELECTRIC FIRE PUMP CONTROLLER

In order to familiarize yourself with the Residential Fire Pump Controller, please read the instruction manual thoroughly and carefully. Retain the manual for future reference.

1. Installation and Mounting of the Controller

Carefully unpack the controller and inspect thoroughly.

The controller should be located as close as is practical to the motor it controls and be within sight of the electric motor.

The controller is designed for either wall or floor mounting. Note that the controller is not free standing and must be mounted with feet or bolted securely to a wall. For dimensional and weight data please refer to the respective data sheets.

2. System Pressure Connection

The Residential Fire Pump Controller is equipped with a Pressure Switch. The controller is provided with a 1/4" NPT female system pressure connection located on the bottom, external side of the enclosure.

NOTE: Water lines to the pressure switch must be free from dirt and contamination.

The pressure should not exceed what the pressure switch is rated for.

3. Electrical Connections

All electrical connections should meet national and local electrical codes and standards.

The controller should be located or so protected that they will not be damaged by water escaping from pumps or pump connections. Current carrying parts of controllers shall be a minimum of 12 inches (305 mm) above the floor level.

- Prior to starting verify all data on the nameplate such as, catalog number, AC line voltage, grounding and system pressure.

- Inspect all electrical connections, components and wiring for any visible damage and correct as necessary. Ensure that all electrical connections are tightened before applying power to the controller.
- Refer to the appropriate field connection drawing included in this manual, for all wiring information pertaining to the incoming AC power supply and motor wiring.
- Install necessary conduit using proper methods and tools.
- Incoming AC line voltage is clearly marked L1, L2, and ground, with terminals located on the main terminal block.

3.1 Wire Sizes

- For control wiring, use #14 AWG wire for all electrical connections.

3.2 Electrical Checkout Instructions

WARNING: *The following procedures should be carried out by a qualified electrician familiar with the electrical safety procedures associated with this product and its associated equipment.*

- 3.2.1 To ensure the pump does not start upon energizing the controller, disconnect the pressure switch (PS). With the controller isolated (circuit breaker CB open), disconnect the control wires from one connection of the pressure switch. If two wires must be removed from the connection, maintain the circuit between the wires by temporarily bolting the two wire lugs together with a machine screw and nut. Temporarily insulate the connection.
- 3.2.2 Adjust the pressure switch set point as described on page 3.
- 3.2.3 Starting and Stopping: With the controller isolated, reconnect the pressure switch. Energize the controller. If the system water pressure is lower than the pressure switch set-point pressure, the pump will start. If the controller is set up for fully automatic operation, the pump will stop when pressure is restored and the running period timer (RPT) has completed its time interval. If the controller is set up for semi-automatic operation, the "STOP" pushbutton must be operated to stop the pump.

For both automatic and semi-automatic operation, if the water pressure is not restored, the pump will stop while the "STOP" pushbutton is held closed. Upon releasing the "STOP" pushbutton, the pump will restart. Each time the "STOP" pushbutton is depressed the RPT timer resets.

If the pump does not start when the controller is energized, or after it has been stopped as described above, operate the "START" pushbutton and check that the pump starts. Operate the "STOP" pushbutton and check that the pump stops; running period timer RPT has no effect in this case.

- 3.2.4 Running Period Timer: The RPT is factory set at 3 minutes. A calibrated dial is provided on the front of the timer to make any adjustments.
- 3.2.5 Sequential Start Timer (Option): The sequential start timer is supplied in duplex pump systems. The lead pump starts as soon as there is a pressure drop, and the lag pump should be set for a 3 - 5 second sequential start delay.

3.3 Pressure Switch Setting Instructions

Before attempting to set the pressure switch, de-energize the fire pump controller by opening the Circuit Breaker. This is done for safety, and so that the fire pump will not start and interfere with the adjustment procedure.

ALCO Pressure Switch

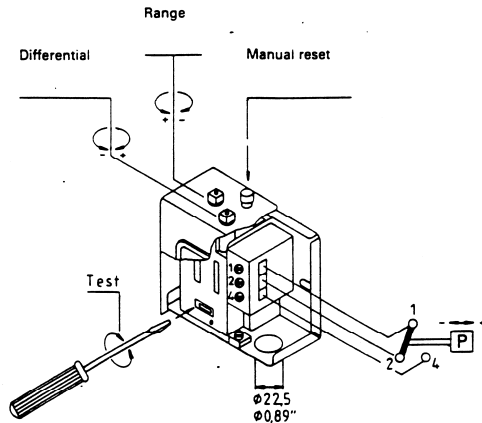

1. Set the differential adjustment on the pressure switch to minimum by turning the Differential Adjusting Screw fully counter clockwise. Set the operating pressure to well below the required pump starting pressure. Turn the Range Adjusting Screw clockwise to reduce the pressure and observe the scale on the switch.
2. Bleed the fire protection water system until the pressure is reduced to the required pump starting pressure. Hold this pressure by closing the drain valve.
3. Slowly rotate the Range Adjusting Screw counter clockwise until a click is heard from the pressure switch. The switch is now set to the required pump starting pressure.
4. If it is necessary to re-adjust the differential, the operating pressure of the switch will also be changed and should be reset.

NOTE: The cut-in (start point) pressure is the cut-out (range adjusting setting) pressure minus the differential setting.

3.4 Circuit Breaker

When the circuit breaker (CB) is in its "OFF" position, the controller is isolated from the power supply and the controller door can be opened. The enclosure door should not be opened with the circuit breaker in the

"ON" position, except by qualified electrical personnel.

The circuit breaker is used to disconnect a running pump motor if necessary. In addition, this thermal magnetic breaker provides overload and short circuit protection

If the breaker trips at the moment of starting the motor, check that the rating of the breaker matches the rating listed on the drawing inside the controller door. Check that the horsepower and voltage of the pump motor match the information listed on the drawing. If everything matches, contact the equipment supplier immediately.

If the breaker trips at any other time, the entire controller/pump system must be checked by a qualified electrician for electrical or mechanical overload, component failure or short circuit.

3.5 Emergency Handle

When pushed and turned counterclockwise, this handle mechanically closes the power contactor and starts the fire pump motor, provided there is electrical power available and the CB is closed.

The microswitch (MSH), is actuated early in the stroke of the emergency handle. The MSH attempts to close the contactor electrically before the power contacts can close mechanically by means of the handle. Without pushing the handle in the full stroke, the pump should continue to run and can be stopped by the STOP pushbutton. If the pump does not continue to run, or the contactor does not latch electrically, push and turn the handle counterclockwise to latch it in place. To turn off the pump, first turn off the CB and then unlatch the handle.

If the emergency starting handle must be used, as the only means to start the fire pump, this shows that there is some malfunction within the controller. The controller should be checked and repaired by a qualified electrician without delay, in order to regain full fire protection.

3.6 Contactor

The contactor connects the pump motor to the supply, under the control of the pressure switch, "START" pushbutton(s) or emergency start handle. Auxiliary contacts provide a signal for supervisory purposes to indicate that the pump is running.

3.7 Pilot Devices

The green "POWER ON" light should be illuminated at all times when the circuit breaker is closed. If it is not then either there is no supply power to the controller or the lamp is burned out. Corrective action should be taken immediately. The green "POWER ON" light also functions as the "START" pushbutton. The "START" pushbutton provides a manual start of the fire pump.

When the pump is running, the red "PUMP RUNNING" light should be illuminated. The red "PUMP RUNNING" light also functions as the "STOP" pushbutton. After a manual start, the "STOP" pushbutton must be used to stop the fire pump. In all fully automatic controllers, if the "START" pushbutton is operated while the pump is already running because of a pressure switch start, the manual stopping provisions take over and the "STOP" pushbutton must be used to stop the fire pump after pressure has been restored.

3.8 Pressure Switch

The pressure switch (PS) is the normal means of starting the fire pump in response to a lowering in water pressure in the fire protection system. The PS contact is closed on low pressure and open on normal water pressure.

3.9 Remote Start/Manual Start Relay

The remote start/manual start relay (ICR) is provided to facilitate the connection of a normally open remotely located starting contact. Installation of this relay allows the use of a remote starting contact rated at 120 volt, 60 Hz with a making capacity of 70 VA and a continuous capacity of 10 VA minimum.

3.12 Low Suction (Option)

An additional pressure switch (LSPS) may be provided to signal low suction pressure by means of a white pilot light on the controller enclosure.

4. Operation of the Controller

4.1 Semi-Automatic or Automatic Operation

Controllers with a pressure switch, but with the Running Period Timer (RPT) disabled, are capable of semi-automatic operation only. Such controllers will start automatically in response to the pressure switch but must be manually stopped with the "STOP" pushbutton. Manual shutdown shall also be provided where required by the authority having jurisdiction.

Controllers fitted with the RPT option are capable of fully automatic operation. Such controllers will start automatically in response to the pressure switch and stop automatically when the pressure has been satisfied and the RPT has timed out. Provision is made to convert automatic controllers to semi-automatic operation by disabling the effect of the RPT. This is done by means of a jumper wire "b" between two points (3 & 3A) on the terminal block as shown on the controller drawing.

For both automatic and semi-automatic operation, if the water pressure is NOT restored, the pump will stop while the STOP pushbutton is held closed. Upon releasing the STOP pushbutton, the pump will restart. Note that the RPT will reset each time the STOP pushbutton is pressed.

Furthermore, if the controller is started manually, either by the local/ remote start pushbutton or emergency handle, then it MUST be stopped manually by depressing the STOP pushbutton.

4.2 Running Period Timer

The running period timer (RPT) in conjunction with the pressure switch (PS) performs the automatic stopping function in a fire pump controller after a start initiated by the pressure switch (PS). The RPT is set in the factory for a delay of 3 minutes. If the pressure switch (PS) responds to a loss of water pressure by closing its contact, the main contactor (M) is energized. The contactor is maintained energized through a normally closed, timed open RPT contact for the preset time interval even if the PS contact re-opens in the interim. At the end of the time interval, the RPT contact opens; if the PS contact is open at that point, meaning system pressure has been restored, M is de-energized and the pump stops. If the PS contact is still closed, M remains energized and the pump continues to run until the PS contact opens.

The purpose of the running period timer is to ensure that the pump motor is not subjected to frequent starts in response to a situation in which the pressure switch (PS) contact repeatedly closes and opens at short time intervals. RPT timing may be reduced for convenience in testing the controller by turning the dial on the front of the timer.

4.3 Sequential Start Timer (Option)

The sequential start timer (SST) delays the starting of the fire pump in response to the closing of the PS contacts. In duplex systems (SST standard on lag pump) it delays starting of the lag pump in addition to any delay added to the lead pump start. It does not delay a pushbutton or emergency handle start. This timing is accomplished by means of an electronic timing device. The timed contacts are used to delay starting the motor for a preset time after the PS contacts close.

This ensures that the starting inrush currents of all the pump motors are not simultaneously imposed on the power supply.

In addition, the provision of a sequential start timer on the lead pump, set to a few seconds delay, will prevent the pump controller from responding to momentary hydraulic transient pressure loss which would otherwise start the fire pump unnecessarily. (This feature may be considered as a "Time Delay Start" option.)

The sequential start timing device can provide a delay from 1-60 seconds. Adjustment is by means of a dial on the front of the timer. The lead pump would normally have its time delay set to minimum and the lag pump would have its time delay set to 5 seconds. If hydraulic transients are a problem, both timers can be adjusted for a few seconds extra time delay.

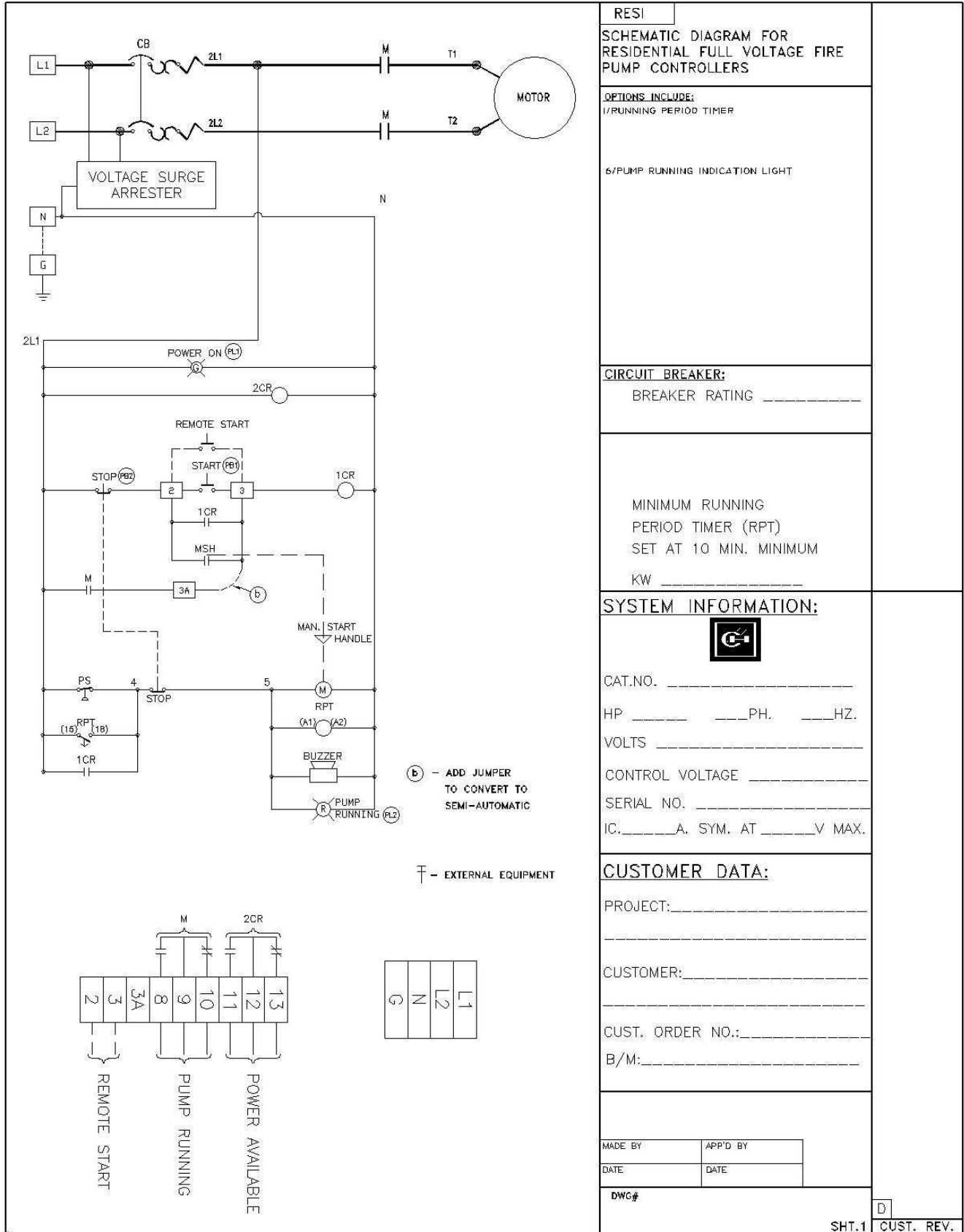
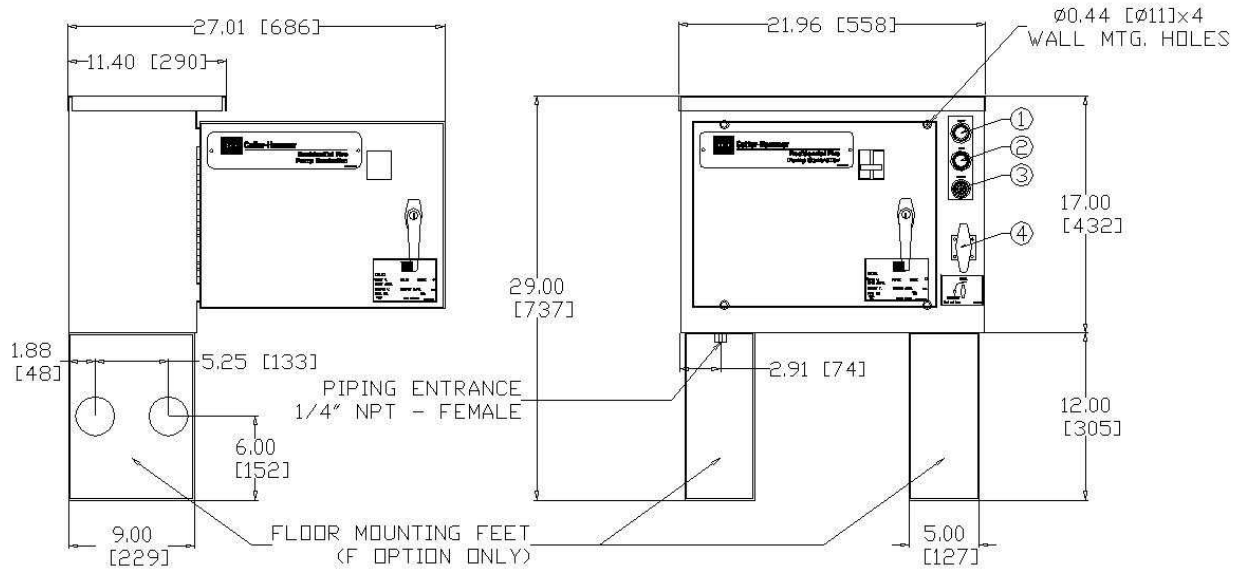

FIGURE #1



Fire Pump Controller Dimensions & Shipping Weights
Residential

RESI



- ① -START PUSHBUTTON / POWER ON LIGHT
- ② -STOP PUSHBUTTON / PUMP RUNNING LIGHT
- ③ -BUZZER
- ④ -MSH (EMERGENCY START HANDLE)
- ⑤ -MAIN POWER SWITCH

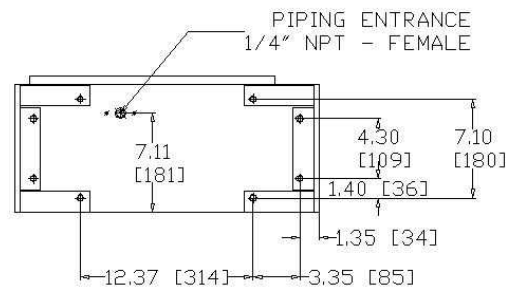

Motor Hp	Line Voltage	Withstand Rating		Approx. Weight Lbs. [Kg]
		Standard	Intermediate	
1-10	230V S/P	10,000	22,000	125 [55]

NOTE:
 1. ALL ENCLOSURES FINISHED IN FIRE PUMP RED
 2. CABLE ENTRANCE EITHER TOP OR BOTTOM
 3. STANDARD ENCLOSURE TYPE NEMA 2
 4. ADD 12" IN HEIGHT FOR OPTIONAL FLOOR STANDS
 DIMENSIONS IN INCHES AND [MILLIMETERS]



Cutler-Hammer

FIGURE #2





© 2009 Eaton Corporation
All Rights Reserved
Printed in Canada
Publication No.: IM05805006K
February 2009

Eaton Corporation
10725 - 25th Street NE Unit 124
Calgary, Alberta, Canada
T3N 0A4
Tel: +1-403-717-2000
Fax: +1-403-717-0567
email: chcfirepump@eaton.com
www.chfire.com