

NFPA13R Packaged Fire Pump System  
UL/FM Fire Pump

# 13-ULV200-R

Compact Residential Package  
Design Condition: 200GPM @ 55PSI

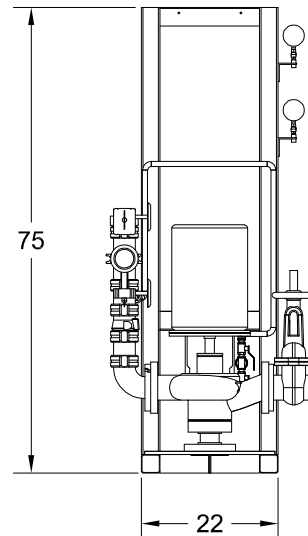
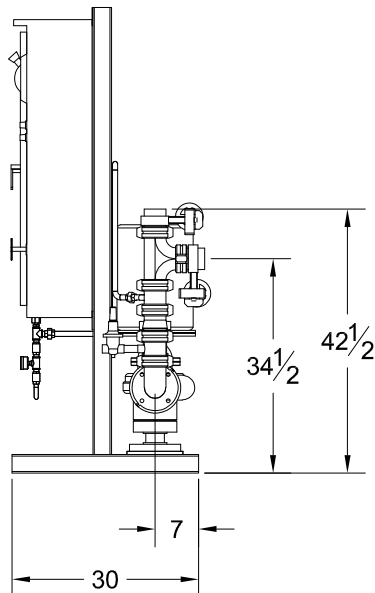
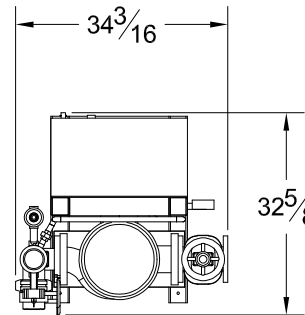
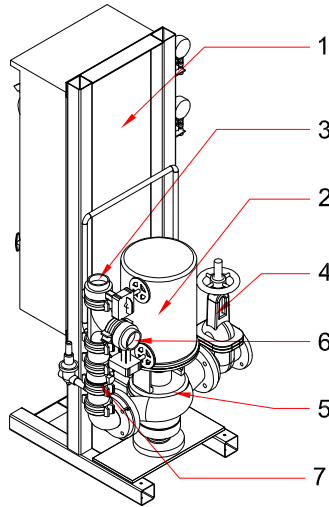

**System Specifications:**

- Motor**
- 10 Horsepower Electric
  - 230 Volt, 46 Amp
  - Single Phase
  - 3450 RPM

- Pump**
- UL/FM Vertical Inline Fire Pump
  - 3" Suction (Flanged)
  - 3" Discharge (Grooved)
  - 175 PSI max working pressure

**System Components (UL Listed by Manufacturer)**

- 1- Limited Service Fire Pump Controller
- 2- Electric Motor
- 3- Discharge Monitored Ball Valve
- 4- Suction OS&Y
- 5- Vertical Inline Fire Pump
- 6- Test Connection Monitored Ball Valve
- 7- Check Valve

**Dimensions (Approximate)**

- 33" Depth
- 75" Height
- 35" Width