

NFPA13R Packaged Fire Pump System
UL/FM Fire Pump

13-ULV100

Compact Residential Package
Design Condition: 100GPM @ 80PSI

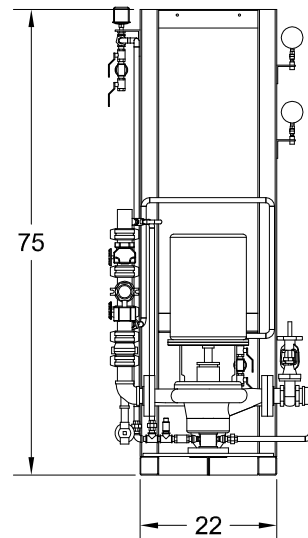
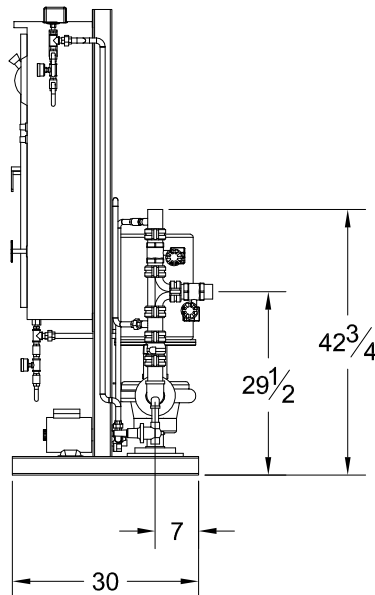
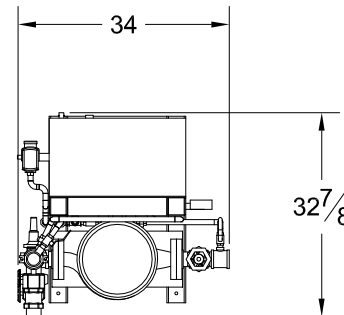
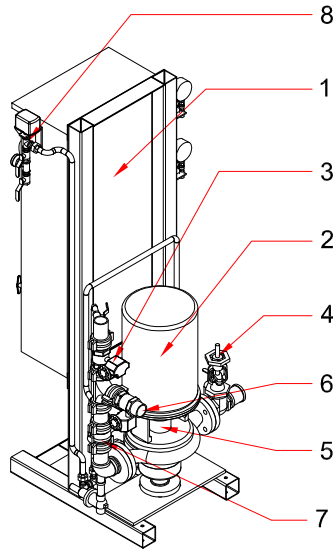

System Specifications:

Motor

- 10 Horsepower Electric
- 230 Volt, 46 Amp
- Single Phase
- 3450 RPM

Pump

- UL/FM Vertical Inline Fire Pump
- 2" Suction (FNPT)
- 2" Discharge (Grooved)
- 175 PSI max working pressure

System Components (UL Listed by Manufacturer)

- 1- Limited Service Fire Pump Controller
- 2- Electric Motor
- 3- Discharge Monitored Ball Valve
- 4- Suction OS&Y
- 5- Vertical Inline Fire Pump
- 6- Test Connection Monitored Ball Valve
- 7- Check Valve
- 8- Pressure Switch (Jockey Control)

Dimensions (Approximate)

- 33" Depth
- 75" Height
- 34" Width