

# ULR-500

w/Flow Meter, Jockey Pump  
Listed Fire Pump & Controller  
NFPA-20 Compliant Packaged System

Controller: \_\_\_\_\_

Jockey Pump: \_\_\_\_\_

Jockey Controller: \_\_\_\_\_

Suction & Discharge: 6" Grooved Fittings

# 500GPM

4 x 5 - 9B & 4 x 5 - 9C

| PSI<br>(range) | Motor<br>HP |
|----------------|-------------|
| 72-75          | 30          |
| 76-100         | 40          |
| 101-120        | 50          |
| 121-130        | 60          |

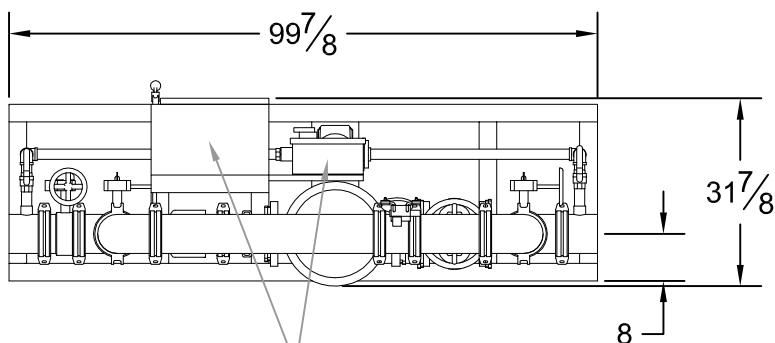

Main Controller &  
Jockey Controller

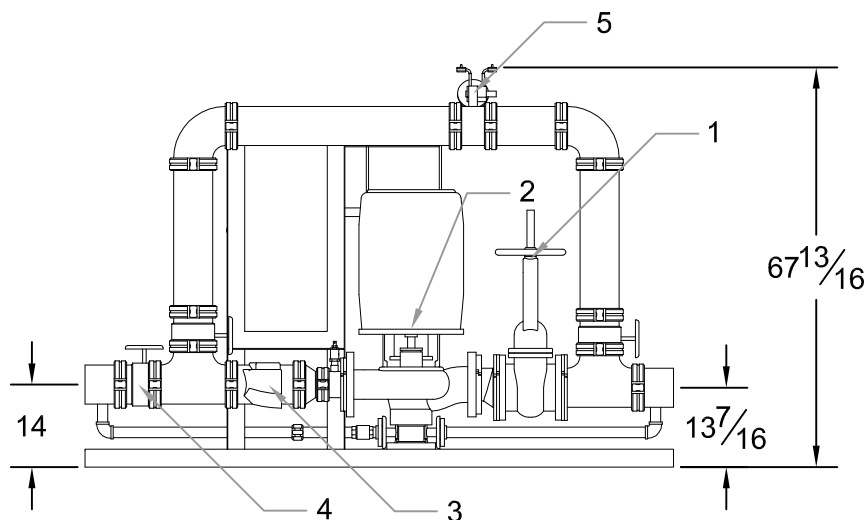

### DESIGN CONDITIONS

\_\_\_\_\_ GPM @ \_\_\_\_\_ PSI  
\_\_\_\_\_ HP \_\_\_\_\_ V \_\_\_\_\_ Phase

Project: \_\_\_\_\_

Contractor: \_\_\_\_\_

Date: \_\_\_\_\_

P.O.: \_\_\_\_\_

### System Components

|   |                     |
|---|---------------------|
| 1 | OS&Y Gate Valve     |
| 2 | Inline Pump & Motor |
| 3 | Check Valve         |
| 4 | Monitored Butterfly |
| 5 | Flow Meter          |

Approximate ship weight: < 1800#