

ULR-400

w/Test Port, Flow Meter, City By-Pass, Jockey Pump
Listed Fire Pump & Controller
NFPA-20 Compliant Packaged System

Controller: _____

Jockey Pump: _____

Jockey Controller: _____

Suction x Discharge: 4" x 4" Grooved Fittings

400GPM

4 x 5 - 9 & 4 x 5 - 9B

PSI (range)	Motor HP
65-75	25
76-90	30
91-110	40
111-120	50
121-136	60

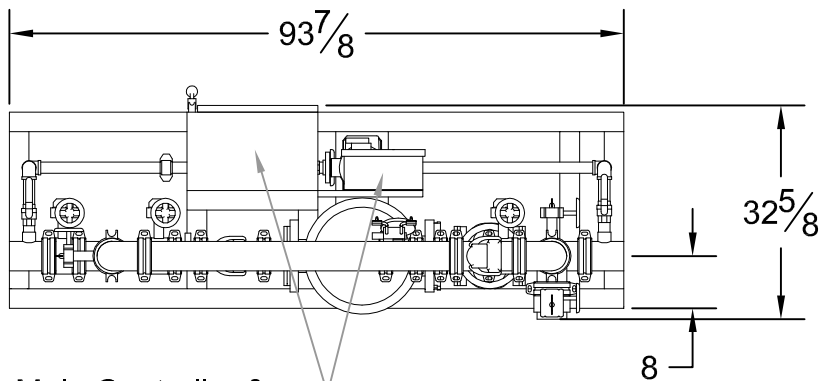

Main Controller &
Jockey Controller

DESIGN CONDITIONS

_____ GPM @ _____ PSI
_____ HP _____ V _____ Phase

Project: _____

Contractor: _____

Date: _____ P.O.: _____

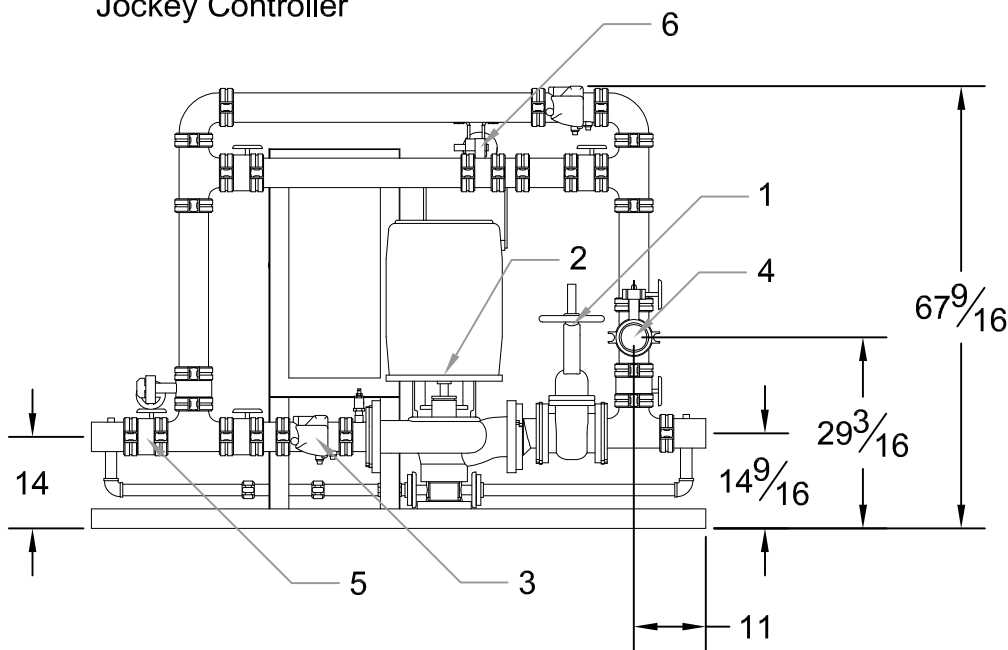

System Components

1	OS&Y Gate Valve
2	Inline Pump & Motor
3	Check Valve
4	Test Port Connection
5	Monitored Butterfly
6	Flow Meter

Approximate ship weight: < 1600#