

ULR-150

w/Test Port, Jockey Pump
Listed Fire Pump & Controller
NFPA-20 Compliant Packaged System

Controller: _____

Jockey Pump: _____

Jockey Controller: _____

Suction x Discharge: 3" x 3" Grooved Fittings

150GPM

3 x 3 - 9A

PSI (range)	Motor HP
61-75	15
76-100	20
101-115	25
116-125	30
126-155	40
156-160	50

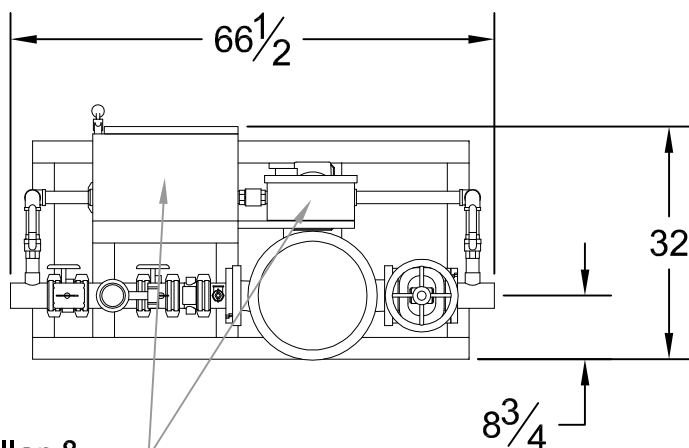

Main Controller &
Jockey Controller

DESIGN CONDITIONS
 _____ GPM @ _____ PSI
 _____ HP _____ V _____ Phase

Project: _____
 Contractor: _____
 Date: _____ P.O.: _____

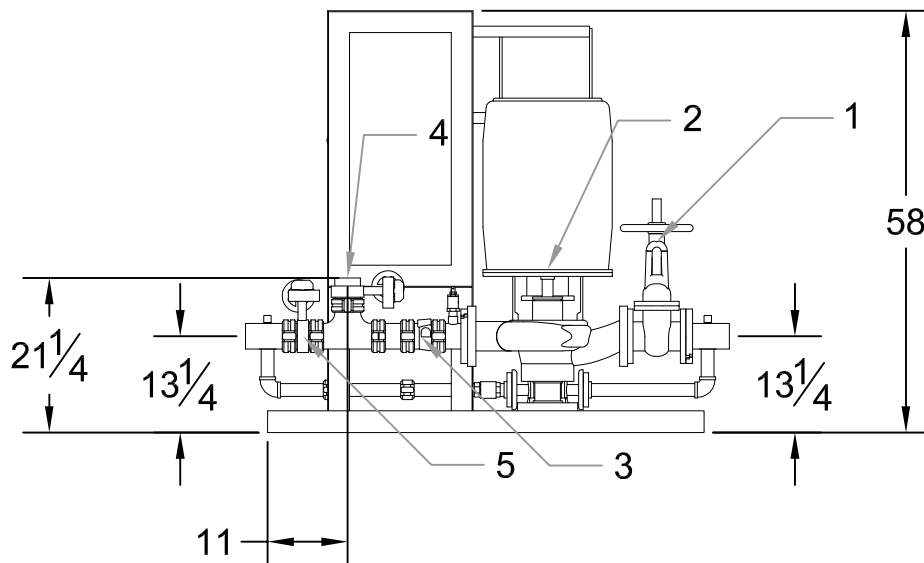

System Components	
1	OS&Y Gate Valve
2	Inline Pump & Motor
3	Check Valve
4	Test Port Connection
5	Monitored Butterfly

Approximate ship weight: < 1200#