

UG-50

Residential Underground
Packaged Fire Pump System
50GPM @ 75PSI

-3 HP 230V Single Phase

-350# System Ship Weight

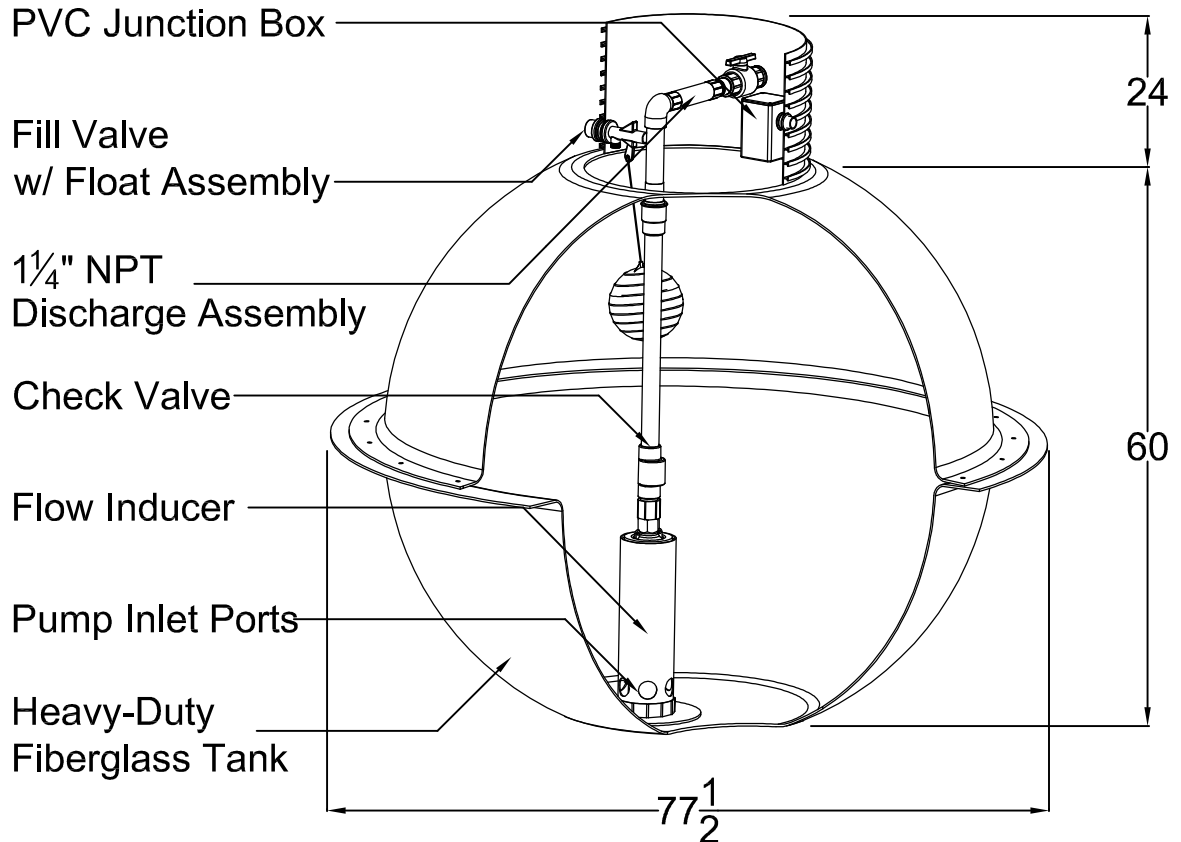
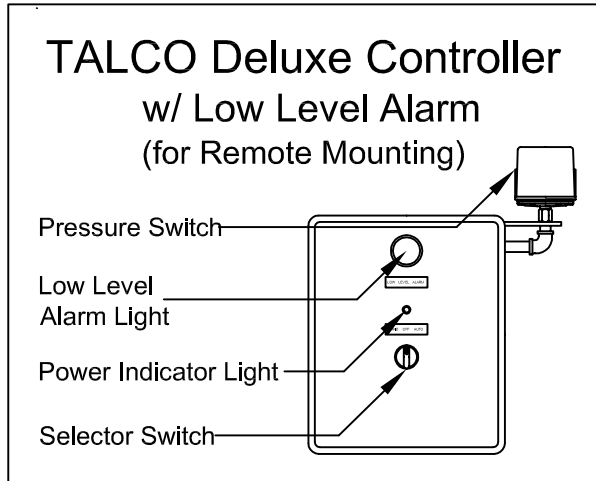

-All dimensions inches-