

Residential Packaged Fire Pump System

HDR-75

Heavy Duty Residential Package
Design Condition: 75GPM @ 70PSI

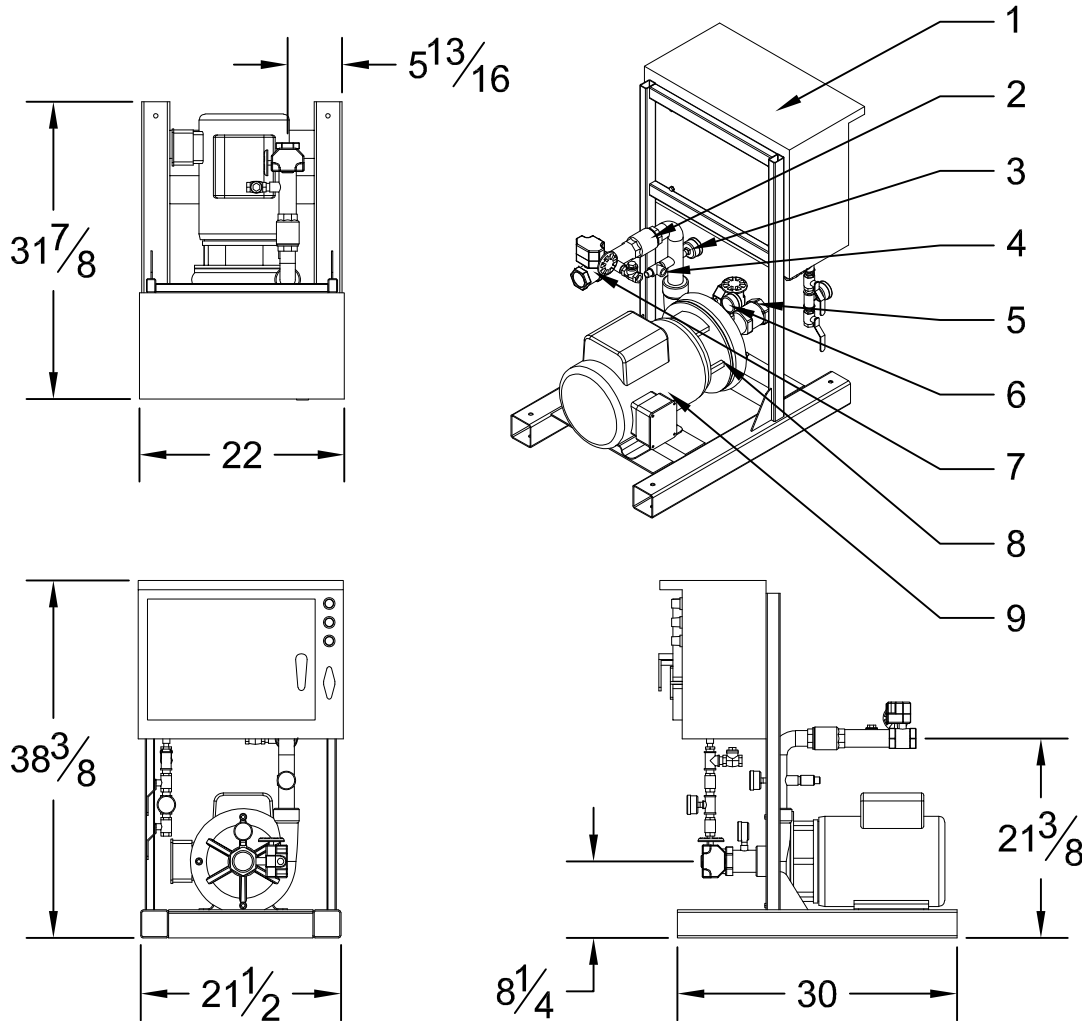

System Specifications:

- Motor**
- 7.5 Horsepower Electric
 - 230 Volt
 - 37 Amp
 - Single Phase
 - 3450 RPM

- Pump**
- End Suction Centrifugal Pump
 - 2" Suction (NPT)
 - 1 1/2" Discharge (NPT)
 - 175 PSI max working pressure

- System Components**
- 1- Residential Fire Pump Controller
 - 2- Check Valve
 - 3- Discharge Pressure Gauge
 - 4- Case Relief Valve
 - 5- Suction Monitored Butterfly Valve
 - 6- Suction Pressure Gauge
 - 7- Discharge Monitored Butterfly Valve
 - 8- End Suction Pump
 - 9- Electric Motor
 - Not Shown- Copper Sensing Line (per NFPA20)

Performance

Performance values based on multiple pump tests. Not for certification purposes.

GPM	0	65	75	85	95	105	115	125
PSI	77	71	70	68	66	64	62	59

Please Note: This fire pump system uses an unlisted pump & a residential controller.

Please submit to your AHJ for approval prior to ordering.