

NFPA-20 Packaged Fire Pump System

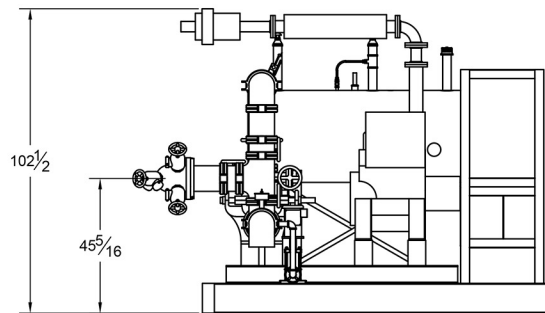
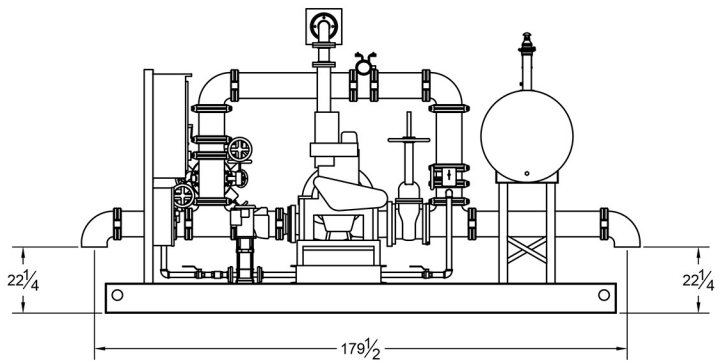
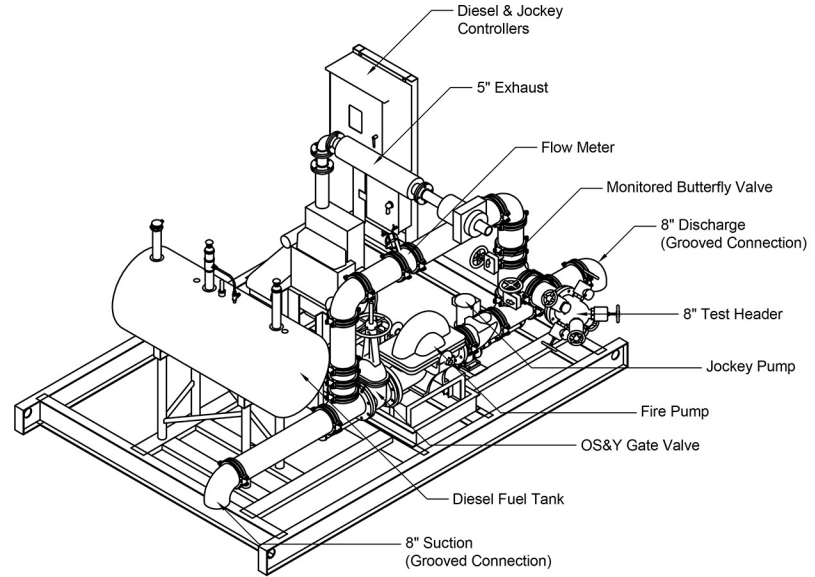
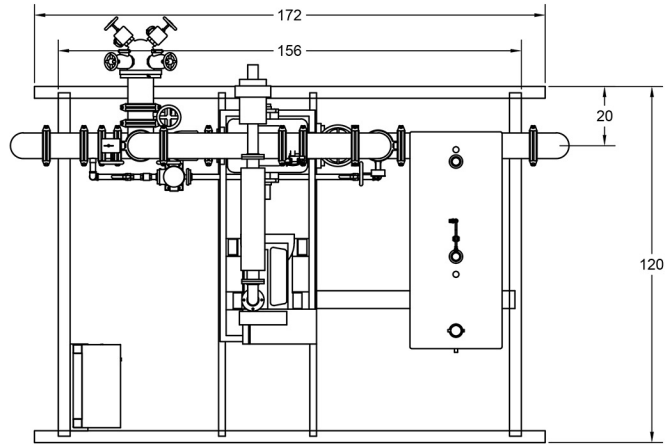

- Diesel Engine:
-Clarke JU4H-UFADW8
- Diesel Pump:
-Aurora 6-491-18B
- Jockey Pump:
-Goulds SVBK
- Controls:
Diesel Controller
-Metron FD4
Jockey Controller
-Metron M15
- Fuel Tank:
-165 Gallon Double Wall

DESIGN CONDITIONS

1500 GPM @ 100 PSI
144 HP 1760 RPM