

NFPA-20 Packaged Fire Pump System

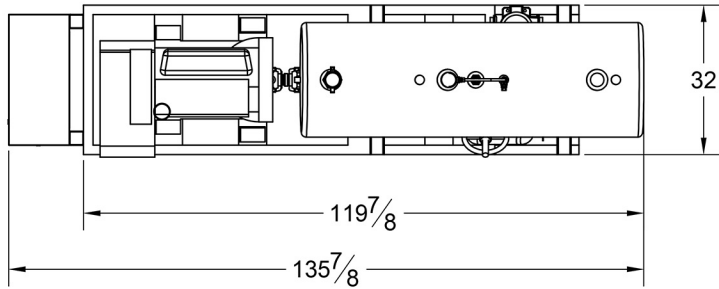

Package overall dimensions to fit through single man-door (36" x 84").

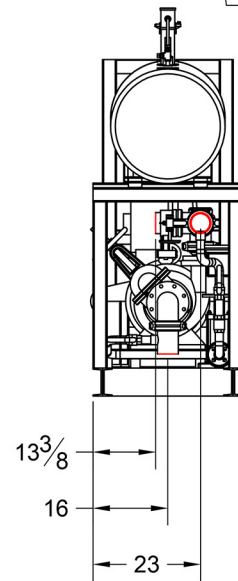
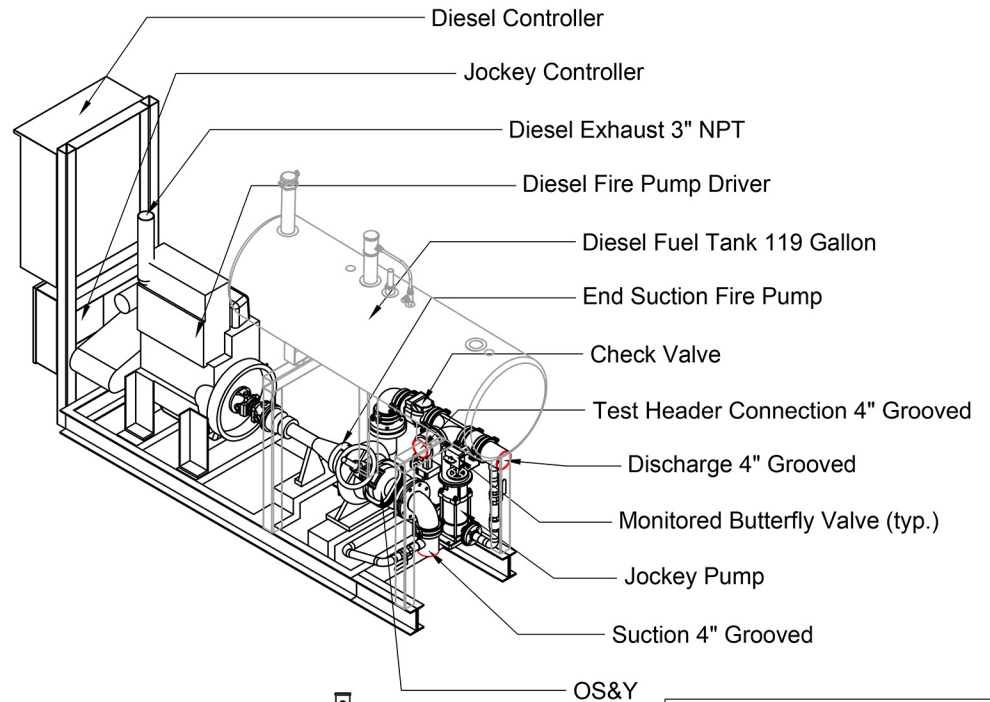
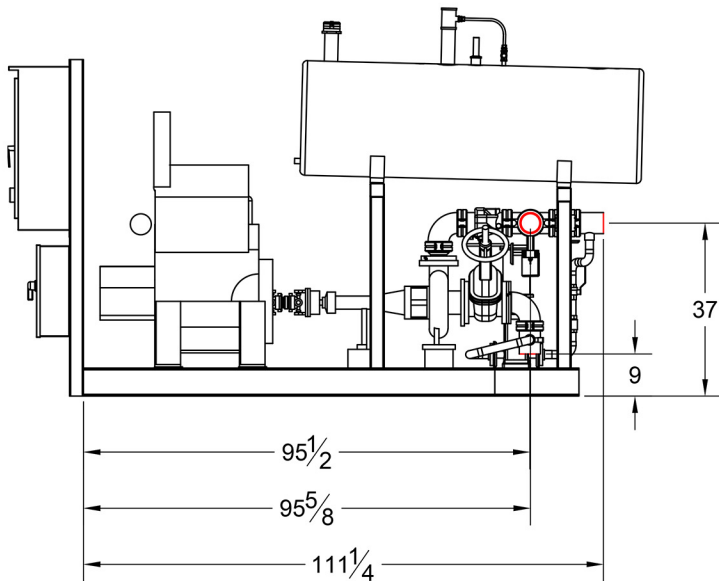

- Diesel Engine:
-Clarke JU4H-UF14
- Diesel Pump:
-Aurora 3-384-11
- Jockey Pump:
-Goulds SVBK
- Diesel Controller:
-Tornatech GPD
- Jockey Controller:
-Tornatech JP2
- Fuel Tank:
-165 Gallon Double Wall

DESIGN CONDITIONS

400 GPM @ 75 PSI
70 HP 2800 RPM