

NFPA13R Packaged Fire Pump System
UL/FM Fire Pump
with Jockey Pump

13-ULV250-R

Compact Residential Package
10HP Design Condition: 250GPM @ 40PSI

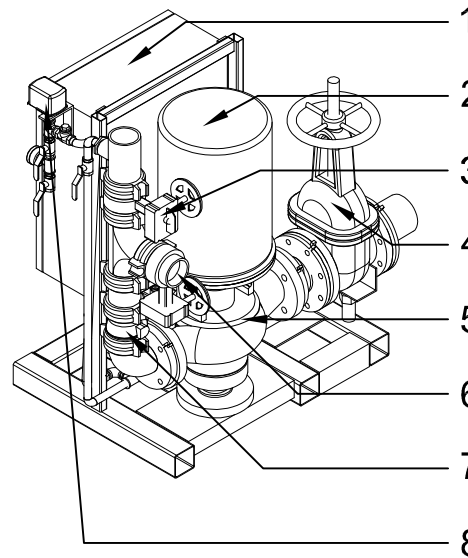
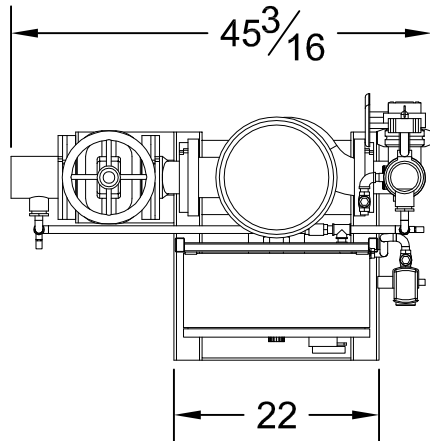

System Specifications:

- Motor (UL Listed by Manufacturer)
- 10 Horsepower Electric, 230 Volt, 46 Amp
- Single Phase
- 3450 RPM

Pump

- UL/FM Vertical Inline Fire Pump
- 4" Suction (Flanged)
- 3" Discharge (Grooved)
- 175 PSI max working pressure

System Components (UL Listed by Manufacturer)

- 1- Limited Service Fire Pump Controller
- 2- Electric Motor
- 3- Discharge Monitored Butterfly Valve
- 4- Suction OS&Y
- 5- Vertical Inline Pump
- 6- Test Connection Monitored Butterfly Valve
- 7- Check Valve
- 8- Pressure Switch (Jockey Control)

Dimensions (Approximate)

- 28" Depth
- 45" Height
- 46" Width

Jockey Pump & Controls

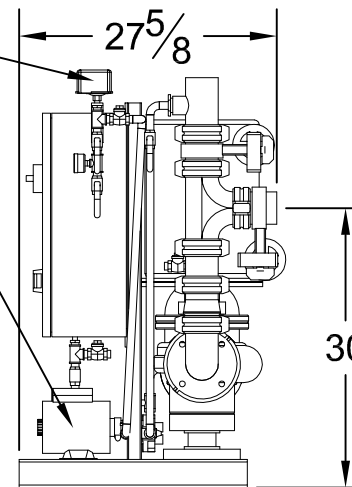
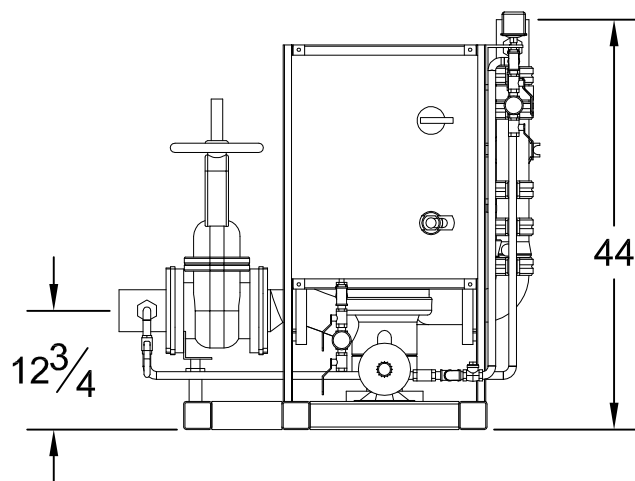

Not Shown - Case Pressure Relief Valve
- Copper Sensing Line (per NFPA20)