

NFPA-13R Packaged Fire Pump System
UL/FM Fire Pump

13-ULV200-R

Compact Residential Package
10HP Design Condition: 200GPM @ 50PSI

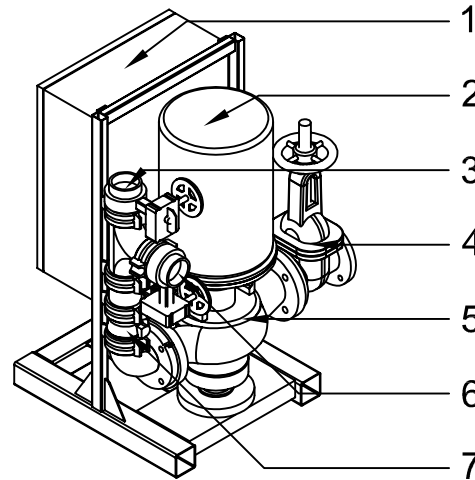
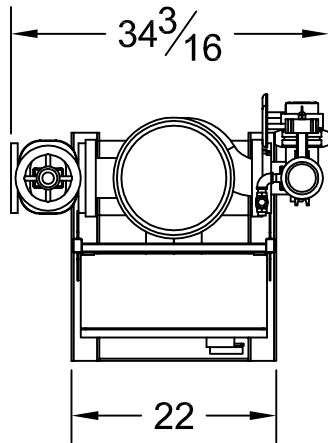

System Specifications:

- Motor (UL Listed by Manufacturer)
- 10 Horsepower Electric, 230 Volt, 46 Amp
- Single Phase
- 3450 RPM

Pump

- UL/FM Vertical Inline Fire Pump
- 3" Suction (Flanged)
- 3" Discharge (Grooved)
- 175 PSI max working pressure

System Components (UL Listed by Manufacturer)

- 1- Limited Service Fire Pump Controller
- 2- Electric Motor
- 3- Discharge Monitored Butterfly Valve
- 4- Suction OS&Y
- 5- Vertical Inline Pump
- 6- Test Connection Monitored Butterfly Valve
- 7- Check Valve
- Not Shown- Case Pressure Relief Valve
Copper Sensing Line (per NFPA20)

Dimensions (Approximate)

- 28" Depth
- 42" Height
- 35" Width

