

ULR-750

w/Test Port, Flow Meter, Jockey Pump
 Listed Fire Pump & Controller
 NFPA-20 Compliant Packaged System

Controller: _____

Jockey Pump: _____

Jockey Controller: _____

Suction & Discharge: 6" Grooved Fittings

750GPM

4 x 6 - 10B

PSI (range)	Motor HP
86-100	60
101-120	75
121-143	100

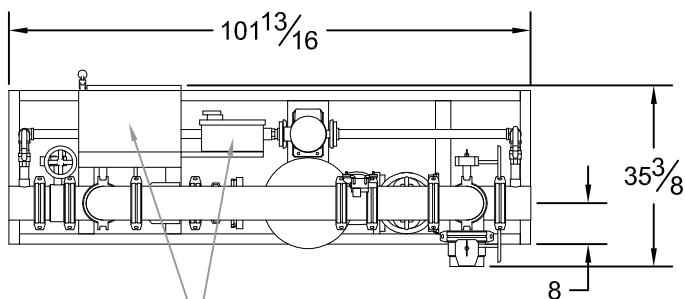

Main Controller & Jockey Controller

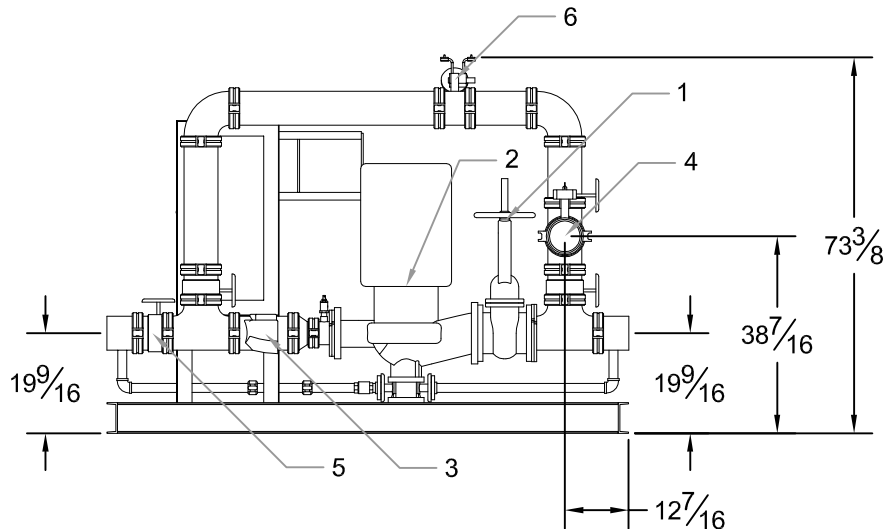

DESIGN CONDITIONS

_____ GPM @ _____ PSI
 _____ HP _____ V _____ Phase

Project: _____

Contractor: _____

Date: _____ P.O.: _____

System Components

1	OS&Y Gate Valve
2	Inline Pump & Motor
3	Check Valve
4	Test Port Connection
5	Monitored Butterfly
6	Flow Meter

Approximate ship weight: < 2250#