

# ULR-500

w/Test Port, Jockey Pump  
Listed Fire Pump & Controller  
NFPA-20 Compliant Packaged System

Controller: \_\_\_\_\_

Jockey Pump: \_\_\_\_\_

Jockey Controller: \_\_\_\_\_

Suction & Discharge: 6" Grooved Fittings

# 500GPM

4 x 5 - 9B & 4 x 5 - 9C

PSI (range)	Motor HP
72-75	30
76-100	40
101-120	50
121-130	60

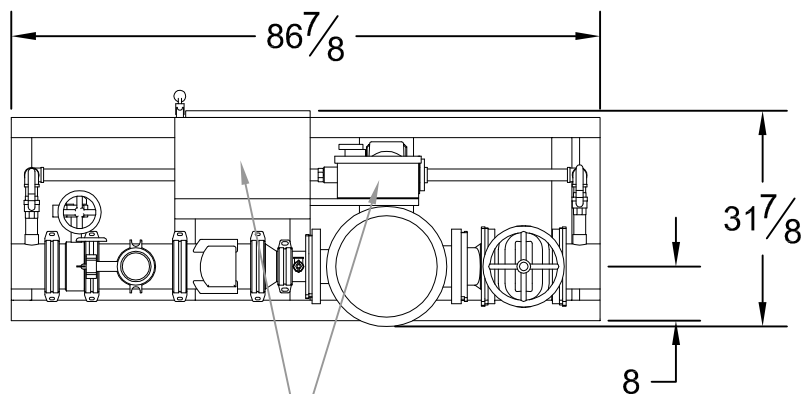

Main Controller &  
Jockey Controller

### DESIGN CONDITIONS

\_\_\_\_\_ GPM @ \_\_\_\_\_ PSI  
\_\_\_\_\_ HP \_\_\_\_\_ V \_\_\_\_\_ Phase

Project: \_\_\_\_\_

Contractor: \_\_\_\_\_

Date: \_\_\_\_\_

P.O.: \_\_\_\_\_

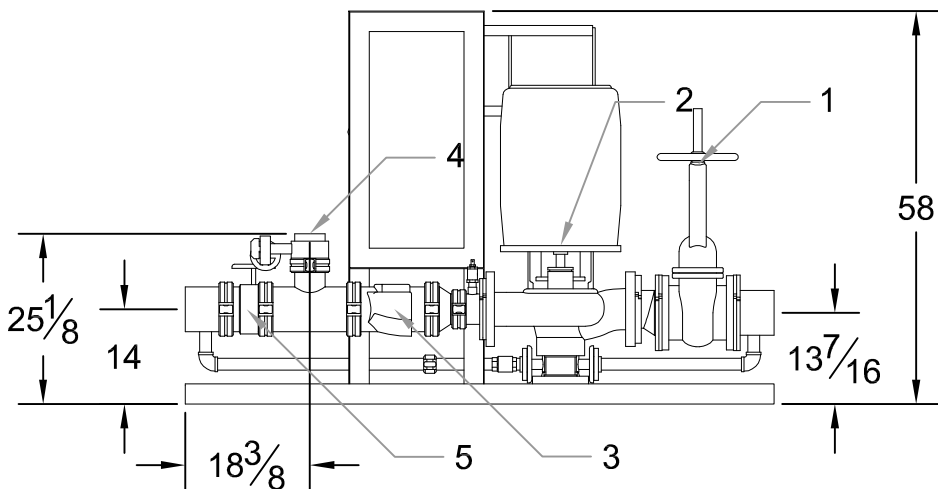

### System Components

1	OS&Y Gate Valve
2	Inline Pump & Motor
3	Check Valve
4	Test Port Connection
5	Monitored Butterfly

Approximate ship weight: < 1800#