

# ULR-500

w/Test Port, Jockey Pump  
Listed Fire Pump & Controller  
NFPA-20 Compliant Packaged System

Controller: \_\_\_\_\_

Jockey Pump: \_\_\_\_\_

Jockey Controller: \_\_\_\_\_

Suction & Discharge: 6" Grooved Fittings

# 500GPM

4 x 4 - 7B

PSI (range)	Motor HP
55-60	25
61-71	30

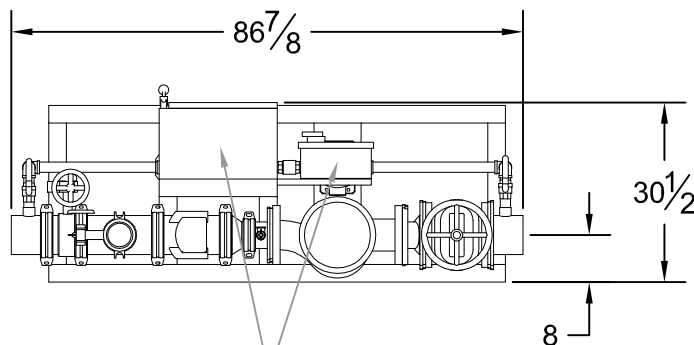

Main Controller &  
Jockey Controller

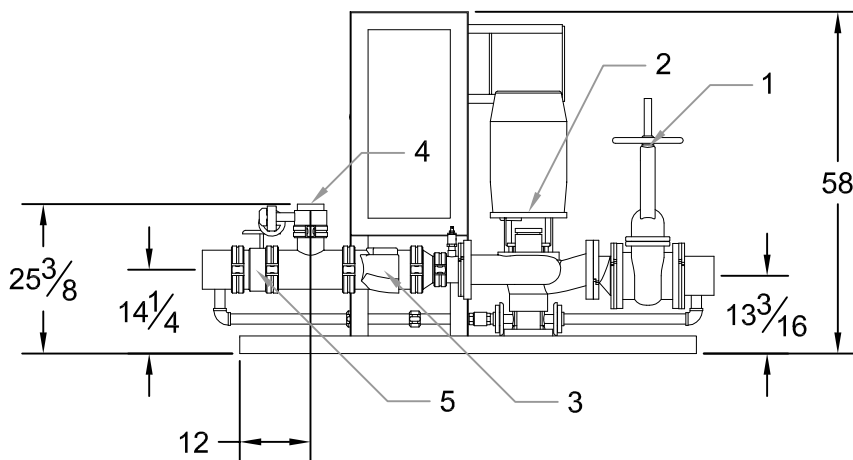

### DESIGN CONDITIONS

\_\_\_\_\_ GPM @ \_\_\_\_\_ PSI  
\_\_\_\_\_ HP \_\_\_\_\_ V \_\_\_\_\_ Phase

Project: \_\_\_\_\_

Contractor: \_\_\_\_\_

Date: \_\_\_\_\_

P.O.: \_\_\_\_\_

### System Components

1	OS&Y Gate Valve
2	Inline Pump & Motor
3	Check Valve
4	Test Port Connection
5	Monitored Butterfly

Approximate ship weight: < 1800#