

ULR-400

w/Test Port, Flow Meter, City By-Pass, Jockey Pump
Listed Fire Pump & Controller
NFPA-20 Compliant Packaged System

Controller: _____

Jockey Pump: _____

Jockey Controller: _____

Suction x Discharge: 4" x 4" Grooved Fittings

400GPM

4 x 4 - 7B

PSI (range)	Motor HP
50-55	20
56-65	25

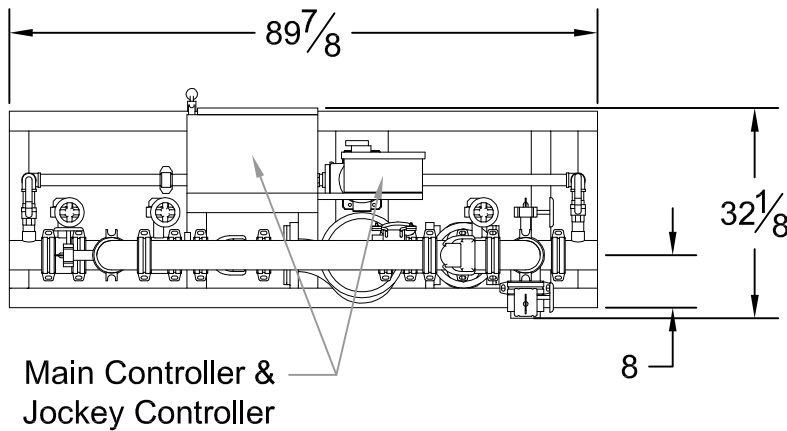

DESIGN CONDITIONS	
_____ GPM @ _____ PSI	
_____ HP _____ V _____ Phase	

Project:	
Contractor:	
Date:	P.O.:

System Components	
1	OS&Y Gate Valve
2	Inline Pump & Motor
3	Check Valve
4	Test Port Connection
5	Monitored Butterfly
6	Flow Meter

Approximate ship weight: < 1200#

