

# ULR-300

w/Test Port, Jockey Pump  
Listed Fire Pump & Controller  
NFPA-20 Compliant Packaged System

Controller: \_\_\_\_\_

Jockey Pump: \_\_\_\_\_

Jockey Controller: \_\_\_\_\_

Suction x Discharge: 4" x 4" Grooved Fittings

# 300GPM

4 x 5 - 9 & 4 x 5 - 9B

PSI (range)	Motor HP
74-85	25
86-95	30
96-115	40
116-125	50
126-139	60

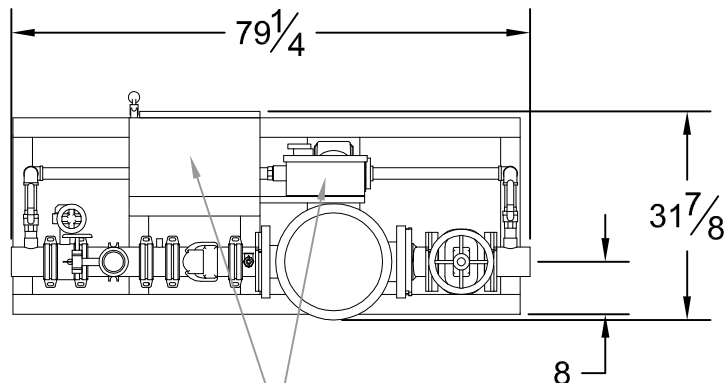

Main Controller &  
Jockey Controller

### DESIGN CONDITIONS

\_\_\_\_\_ GPM @ \_\_\_\_\_ PSI  
\_\_\_\_\_ HP \_\_\_\_\_ V \_\_\_\_\_ Phase

Project: \_\_\_\_\_

Contractor: \_\_\_\_\_

Date: \_\_\_\_\_ P.O.: \_\_\_\_\_

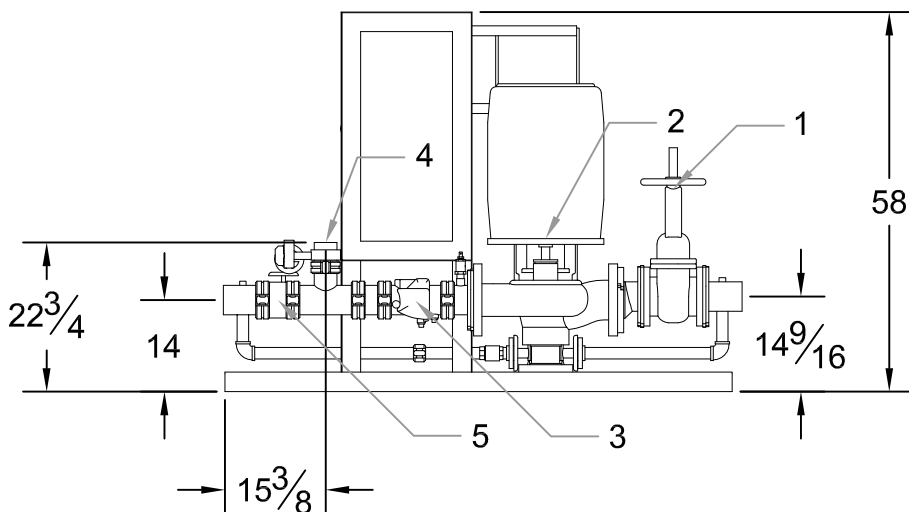

### System Components

1	OS&Y Gate Valve
2	Inline Pump & Motor
3	Check Valve
4	Test Port Connection
5	Monitored Butterfly

Approximate ship weight: < 1500#