

ULR-300

w/Test Port, City By-Pass, Jockey Pump
Listed Fire Pump & Controller
NFPA-20 Compliant Packaged System

Controller: _____

Jockey Pump: _____

Jockey Controller: _____

Suction x Discharge: 4" x 4" Grooved Fittings

300GPM

4 x 5 - 9 & 4 x 5 - 9B

PSI (range)	Motor HP
74-85	25
86-95	30
96-115	40
116-125	50
126-139	60

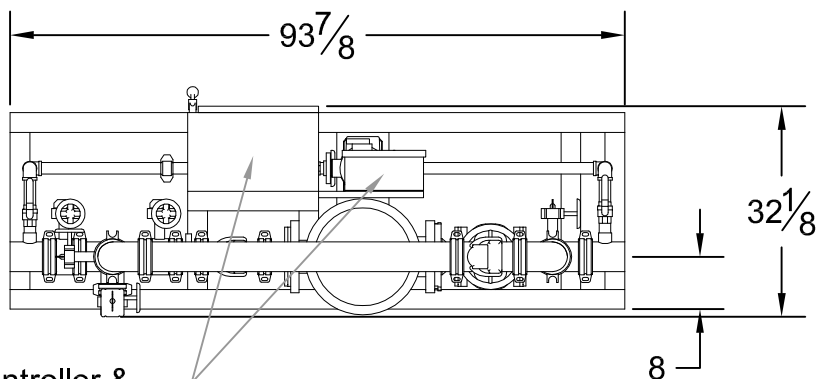

Main Controller & Jockey Controller

DESIGN CONDITIONS

_____ GPM @ _____ PSI
_____ HP _____ V _____ Phase

Project: _____

Contractor: _____

Date: _____ P.O.: _____

System Components

1	OS&Y Gate Valve
2	Inline Pump & Motor
3	Check Valve
4	Test Port Connection
5	Monitored Butterfly

Approximate ship weight: < 1500#

