

ULR-250

w/Test Port, Jockey Pump
Listed Fire Pump & Controller
NFPA-20 Compliant Packaged System

Controller: _____

Jockey Pump: _____

Jockey Controller: _____

Suction x Discharge: 4" x 3" Grooved Fittings

250GPM

3 x 4 - 9

PSI (range)	Motor HP
66-85	20
86-100	25
101-115	30
116-135	40
136-138	50

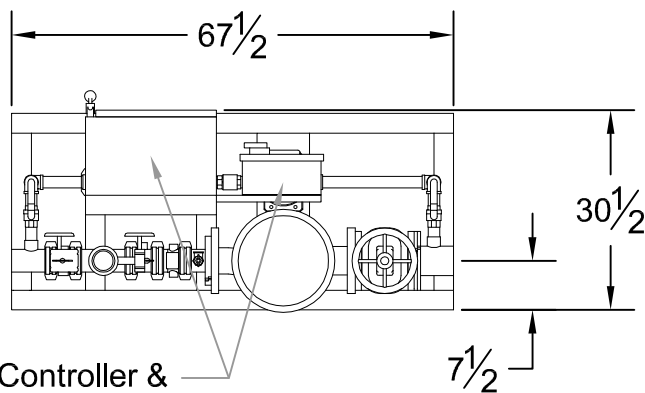

Main Controller &
Jockey Controller

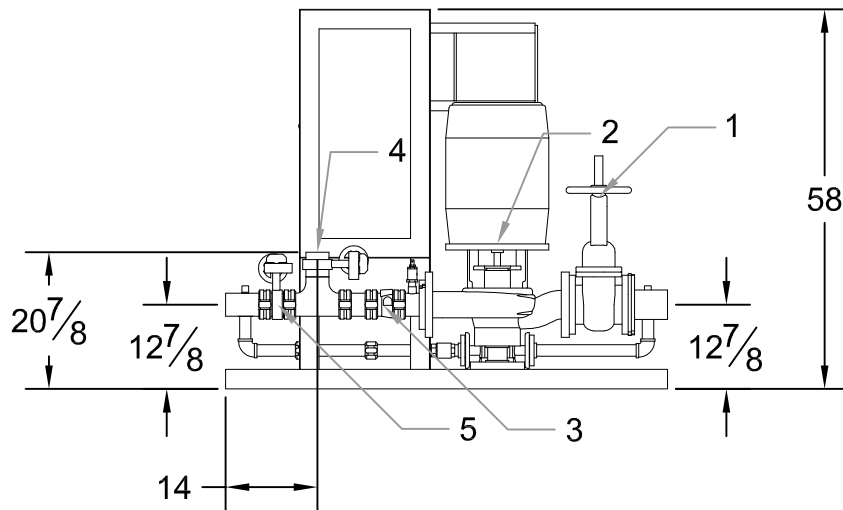

DESIGN CONDITIONS

_____ GPM @ _____ PSI
_____ HP _____ V _____ Phase

Project: _____

Contractor: _____

Date: _____ P.O.: _____

System Components

1	OS&Y Gate Valve
2	Inline Pump & Motor
3	Check Valve
4	Test Port Connection
5	Monitored Butterfly

Approximate ship weight: < 1250#