

# ULR-200

w/Test Port, City By-Pass, Jockey Pump  
Listed Fire Pump & Controller  
NFPA-20 Compliant Packaged System

Controller: \_\_\_\_\_

Jockey Pump: \_\_\_\_\_

Jockey Controller: \_\_\_\_\_

Suction x Discharge: 3" x 3" Grooved Fittings

# 200GPM

3 x 3 - 7A

PSI (range)	Motor HP
40	7½
41-50	10
51-55	15

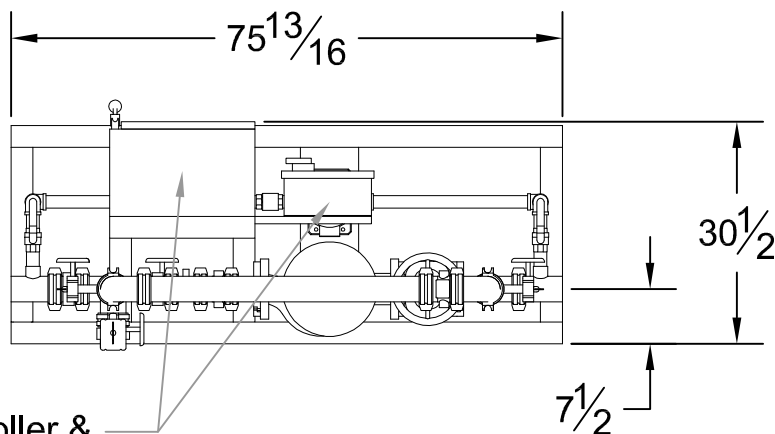

Main Controller &  
Jockey Controller

DESIGN CONDITIONS  
 \_\_\_\_\_ GPM @ \_\_\_\_\_ PSI  
 \_\_\_\_\_ HP \_\_\_\_\_ V \_\_\_\_\_ Phase

Project: \_\_\_\_\_  
 Contractor: \_\_\_\_\_  
 Date: \_\_\_\_\_ P.O.: \_\_\_\_\_

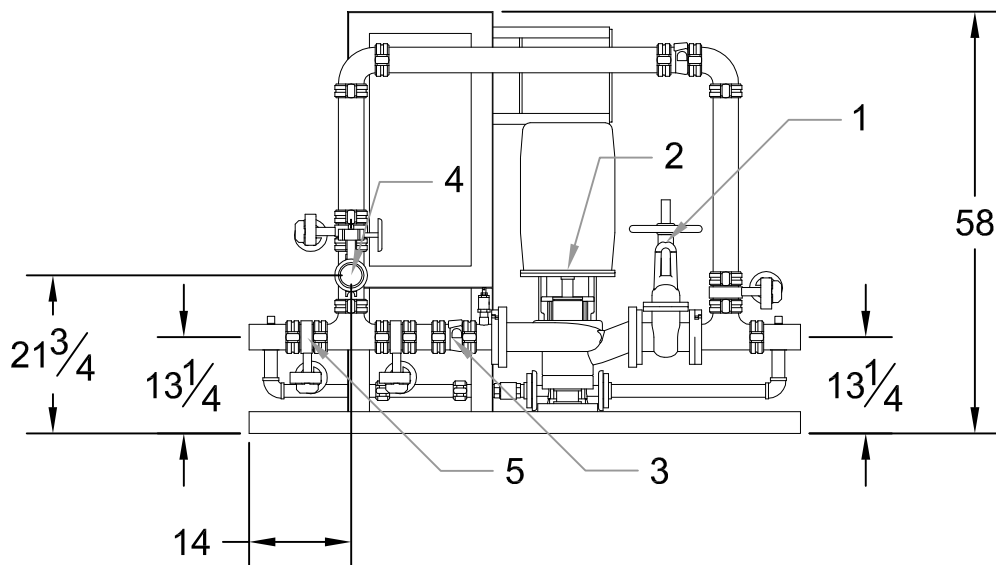

System Components	
1	OS&Y Gate Valve
2	Inline Pump & Motor
3	Check Valve
4	Test Port Connection
5	Monitored Butterfly

Approximate ship weight: < 950#