

# ULR-150

w/Test Port, Jockey Pump  
 Listed Fire Pump & Controller  
 NFPA-20 Compliant Packaged System

Controller: \_\_\_\_\_

Jockey Pump: \_\_\_\_\_

Jockey Controller: \_\_\_\_\_

Suction x Discharge: 3" x 3" Grooved Fittings

# 150GPM

3 x 3 - 7A

PSI (range)	Motor HP
41-50	7½
51-60	10

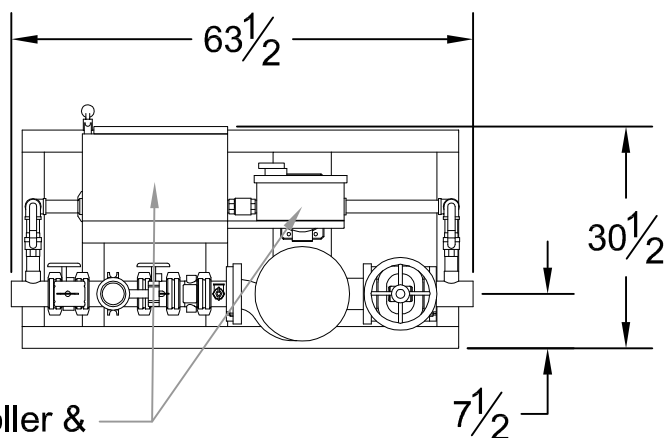

Main Controller & Jockey Controller

<b>DESIGN CONDITIONS</b>	
_____ GPM @ _____ PSI	
_____ HP _____ V _____ Phase	

Project:	
Contractor:	
Date:	P.O.:

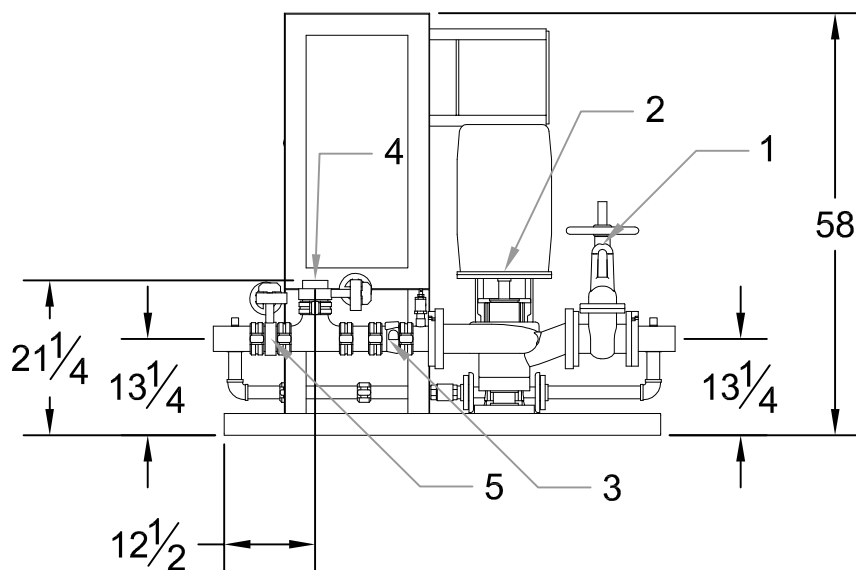

System Components	
1	OS&Y Gate Valve
2	Inline Pump & Motor
3	Check Valve
4	Test Port Connection
5	Monitored Butterfly

Approximate ship weight: < 1000#