

ULR-150

w/Flow Meter, Jockey Pump
Listed Fire Pump & Controller
NFPA-20 Compliant Packaged System

Controller: _____

Jockey Pump: _____

Jockey Controller: _____

Suction x Discharge: 3" x 3" Grooved Fittings

150GPM

3 x 3 - 7A

PSI (range)	Motor HP
41-50	7½
51-60	10

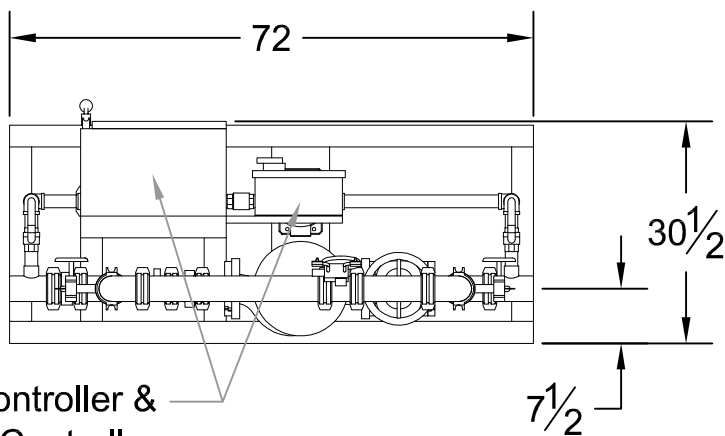

Main Controller & Jockey Controller

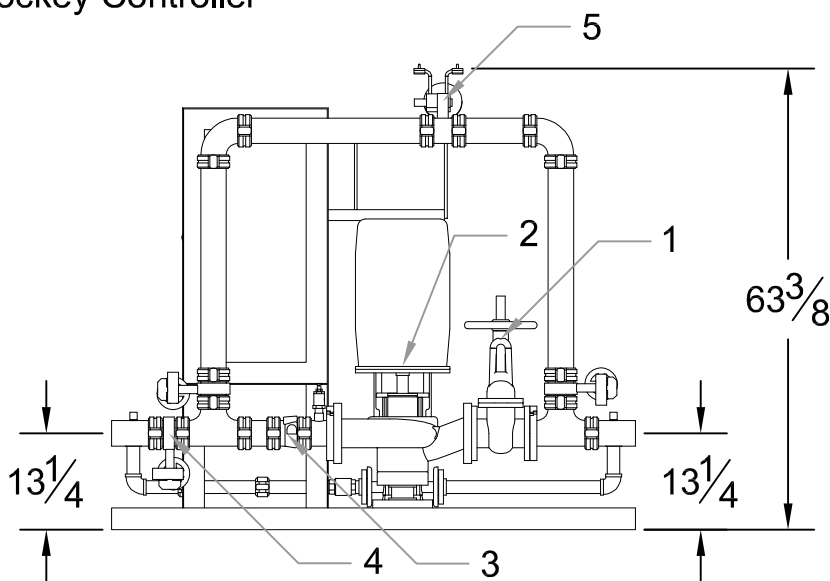

DESIGN CONDITIONS
 _____ GPM @ _____ PSI
 _____ HP _____ V _____ Phase

Project: _____
 Contractor: _____
 Date: _____ P.O.: _____

System Components	
1	OS&Y Gate Valve
2	Inline Pump & Motor
3	Check Valve
4	Monitored Butterfly
5	Flow Meter

Approximate ship weight: < 1000#