

# ULR-100

w/Test Port, Flow Meter, Jockey Pump  
Listed Fire Pump & Controller  
NFPA-20 Compliant Packaged System

Controller: \_\_\_\_\_

Jockey Pump: \_\_\_\_\_

Jockey Controller: \_\_\_\_\_

Suction x Discharge: 3" Grooved x 2 1/2" Grooved

# 100GPM

2 x 2 - 9C

| PSI (range) | Motor HP |
|-------------|----------|
| 66-90       | 10       |
| 91-115      | 15       |
| 116-130     | 20       |
| 131-150     | 25       |

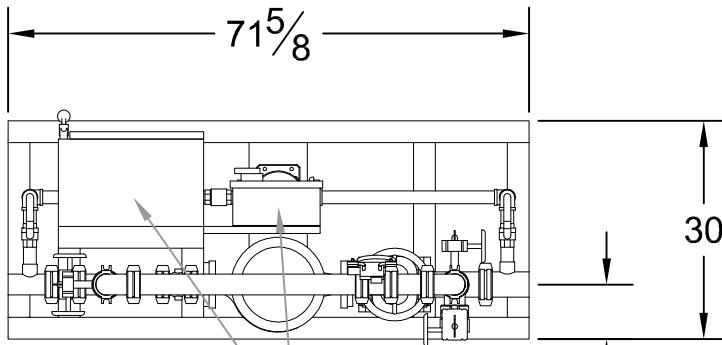

Main Controller &  
Jockey Controller

7 1/2"

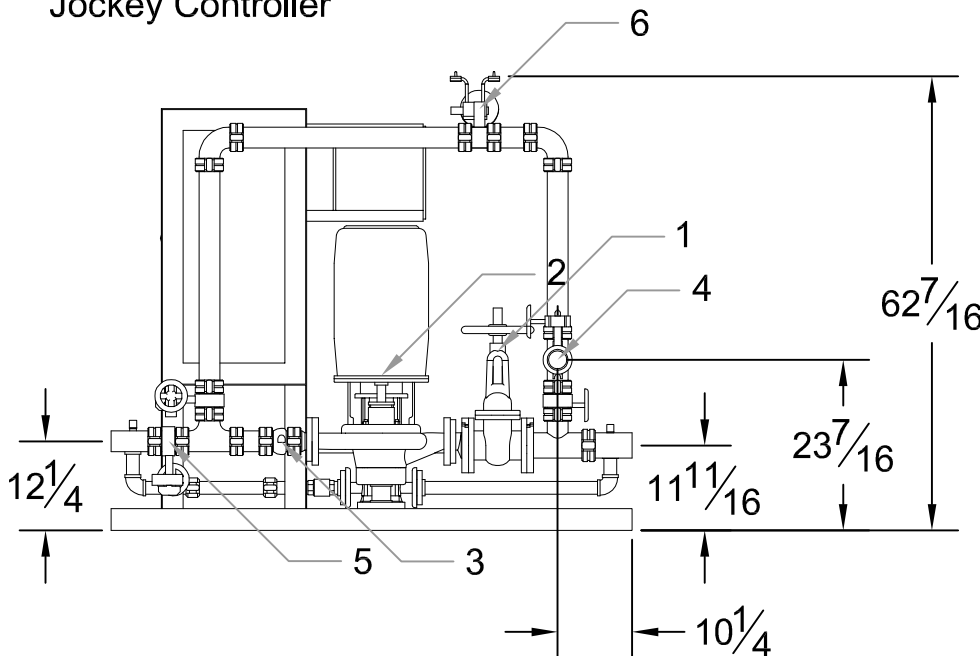

### DESIGN CONDITIONS

\_\_\_\_\_ GPM @ \_\_\_\_\_ PSI  
\_\_\_\_\_ HP \_\_\_\_\_ V \_\_\_\_\_ Phase

Project: \_\_\_\_\_

Contractor: \_\_\_\_\_

Date: \_\_\_\_\_

P.O.: \_\_\_\_\_

### System Components

|   |                      |
|---|----------------------|
| 1 | OS&Y Gate Valve      |
| 2 | Inline Pump & Motor  |
| 3 | Check Valve          |
| 4 | Test Port Connection |
| 5 | Monitored Butterfly  |
| 6 | Flow Meter           |

Approximate ship weight: < 900#