

# ULR-50

w/Test Port, Flow Meter, City By-Pass, Jockey Pump  
Listed Fire Pump & Controller  
NFPA-20 Compliant Packaged System

Controller: \_\_\_\_\_

Jockey Pump: \_\_\_\_\_

Jockey Controller: \_\_\_\_\_

Suction x Discharge: 2" GRV x 2" GRV

# 50GPM

2 x 2 - 9C

PSI (range)	Motor HP
75-95	10
96-120	15
121-135	20
136-155	25

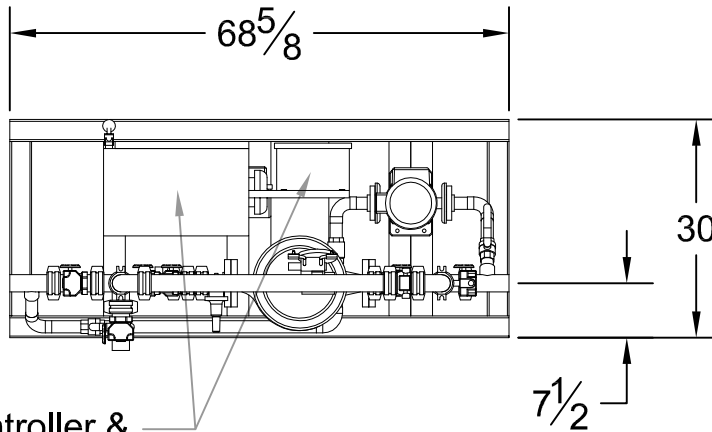

Main Controller &  
Jockey Controller

**DESIGN CONDITIONS**  
 \_\_\_\_\_ GPM @ \_\_\_\_\_ PSI  
 \_\_\_\_\_ HP \_\_\_\_\_ V \_\_\_\_\_ Phase

Project: \_\_\_\_\_  
 Contractor: \_\_\_\_\_  
 Date: \_\_\_\_\_ P.O.: \_\_\_\_\_

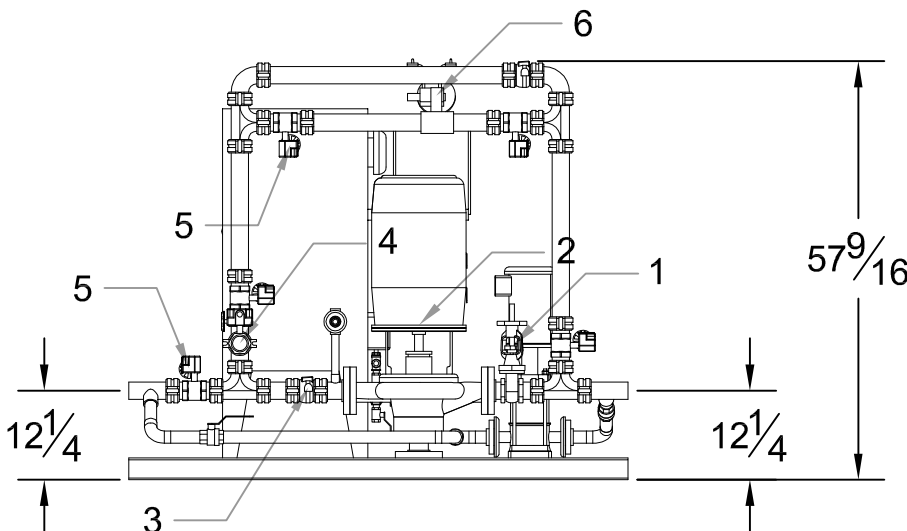

**System Components**

1	OS&Y Gate Valve
2	Inline Pump & Motor
3	Check Valve
4	Test Port Connection
5	Monitored Butterfly
6	Flow Meter

Approximate ship weight: < 900#