

LSF-500CIG

Compact Residential Package

60GPM @ 70PSI

System Specifications

Motor

- 5 horsepower electric
- 230 Volt, 21.5 Amp
- Single Phase
- 3450 RPM

Pump

- High pressure cast iron volute
- Machined bronze impeller
- 2" Suction
- 1¼" Discharge
- 150 PSI Max Working Pressure

Discharge Manifold

- Check Valve
- Zero to 100 PSI pressure gauge
- 40/60 pressure switch
- Isolation ball valve

Controls

- 230 Volt
- Minimum run timer
- Pressure switch operated contactor
- HOA toggle switch (Hand, Off, Auto)

Dimensions (approximate)

- 22⁵/₁₆" Length
- 20¹/₂" Height
- 14³/₈" Width
- 135 pounds

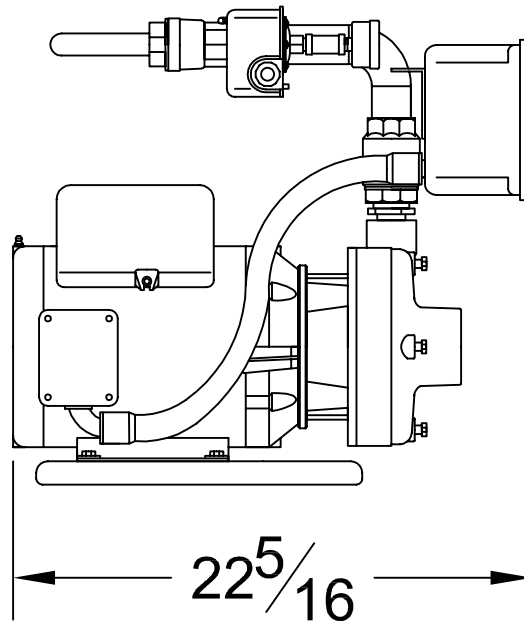
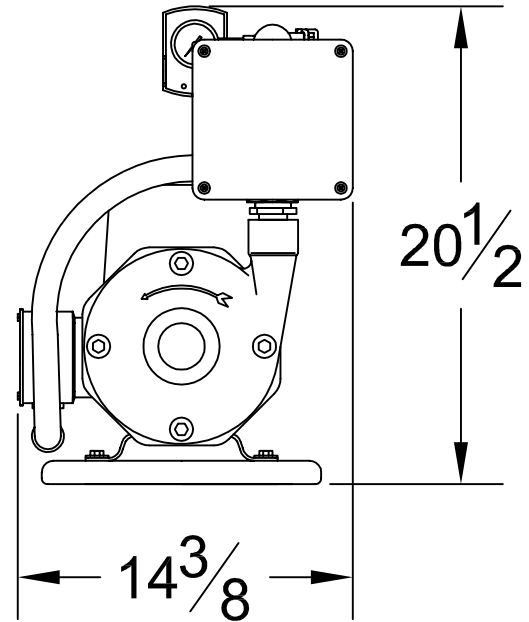

Performance

Performance values based on multiple pump tests. Not for certification purposes.

GPM	0	20	30	40	50	60	70
PSI	85	83	81	79	75	71	66