

Residential Packaged Fire Pump System

HDR-150

Heavy Duty Residential Package
Design Condition: 150GPM @ 65PSI

System Specifications:

- Motor
 - 10 Horsepower Electric
 - 230 Volt
 - 46 Amp
 - Single Phase
 - 3450 RPM
- Pump
 - End Suction Centrifugal Pump
 - 3" Suction (Flanged)
 - 2 1/2" Discharge (Grooved)
 - 175 PSI max working pressure

- System Components
 - 1- Residential Fire Pump Controller
 - 2- Check Valve
 - 3- Discharge Monitored Butterfly Valve
 - 4- Case Relief Valve
 - 5- Electric Motor
 - 6- Suction Pressure Gauge
 - 7- End Suction Pump
 - 8- Discharge Pressure Gauge
 - 9- Suction OS&Y
 - Not Shown- Copper Sensing Line (per NFPA20)

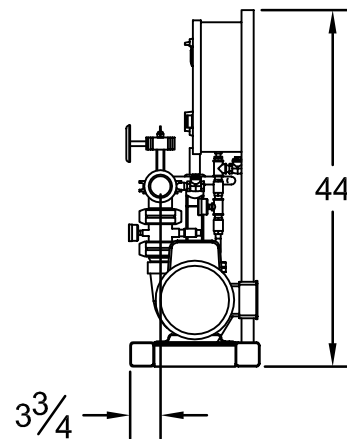
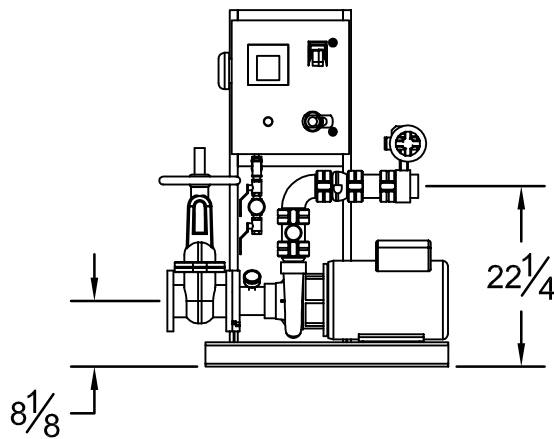
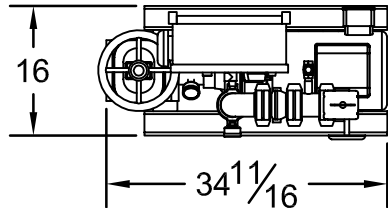
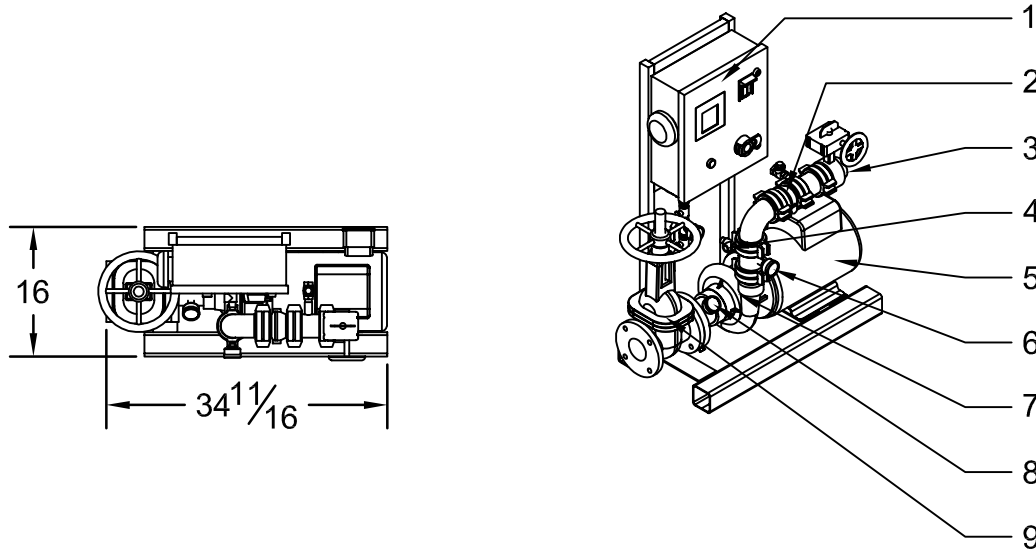

Performance

Performance values based on multiple pump tests. Not for certification purposes.

GPM	0	60	90	110	150	180	200	225
PSI	72	72	71	70	67	64	62	57

Please Note: This fire pump system uses an unlisted pump & a residential controller. Please submit to your AHJ for approval prior to ordering.